



UST
FACULTAT DE CIÈNCIES
I TECNOLOGIA
UVIC-UCC

Degree Final Project

*Local-Global Paradigm: Auditory
Neurostimulation*

Lorena Casanova Lozano

Degree in Biomedical Engineering

Tutor: Jordi Solé-Casals

Endorser: Josep Dinarés

Vic, January, 2019

1 Index

2	Abstract.....	2
3	Resum	3
4	Introduction	4
5	Motivation	5
6	Objectives	5
7	State of art	6
7.1	Disorders of Consciousness.....	6
7.2	Brain Computer Interfaces (BCI)	6
7.3	Electroencephalography (EEG).....	7
7.4	Event Related Potentials (ERPs)	8
7.5	Amplification of brain signals.....	10
7.6	Signal Processing Methods.....	11
7.6.1	Filtering	11
7.6.2	Artefact Rejection	13
7.7	Statistics	14
8	Materials and Methods.....	15
8.1	Auditory stimulation	15
8.2	Hardware.....	16
8.2.1	EEG cap and Electrode System.....	16
8.2.2	USB amp.....	17
8.2.3	TRIGGER box	17
8.3	Assembly	18
8.4	Software	18
8.4.1	System-Function	18
8.4.2	Model generator	20
8.4.3	Signal Processing and Features Extraction.....	23
8.5	Signal Acquisition	26
8.5.1	Subjects	26
8.5.2	EEG recordings	26
9	Results.....	28
9.1	Pre-processing data.....	28
9.2	t-test based statistics	28
9.3	Auditory model of neurostimulation	28

9.4	Event-Related Potentials.....	28
9.4.1	Global Effects	28
9.4.2	Local Effects	31
10	Conclusion	33
11	References.....	35
12	Annex.....	37
13	Video	41

2 Abstract

A major scientific challenge in the area of neuroscience is to detect some conscious processing in patients with disorders of consciousness. In this Final Degree Project has been designed a paradigm that evaluates cerebral responses to violations of temporal regularities that are either local in time or global across several seconds. The goal is being able to differentiate patients in a vegetative state from those in a minimally conscious or conscious state through Electro-Encephalography (EEG) signals. An EEG cap with 16 channels has been used to detect the Evoked Related Potentials (ERP) components in the response of the auditory stimulus. The sounds have been presented to some voluntaries through a Graphical Interface from MATLAB Simulink in where the signals have also been taken, amplified and recorded at real time.

The auditory odd-ball paradigm consists in series of five sounds with some different sounds between them in order to induce a change in brain signals of the listener. These changes, called Evoked Related Potentials, have been isolated and observed to predict the future diagnosis of patients with disorders of consciousness. If people without the ability to interact with their environment present some peaks in their brain potential, it is possible that they may wake up soon.

A Simulink model from MATLAB has been designed and programmed to make a way of communication between the biological signals of brain and the computer. Acquisition systems from g.tec medical engineering have also been used. Then, these signals have been processed to obtain the resulting graphics of voltage in function of time.

Some voluntary people have been requested to do the experiment. It has been possible to register the brain signals from four healthy people and only one patient with brain disease has been presented. It is not possible to confirm that the presented system in this project can predict the response of patients with a disorder of consciousness according to the number of people used to test it. But a first approach of the pattern that would follow the brain signals in this type of patients can be established.

Keywords: Non-communicating Patients, Consciousness, Global Violations, Local Violations, Deviant Series, Standard Series, Brain Potentials, Signal Processing.

Abbreviations: Electroencephalography (EEG), Evoked Related Potentials (ERP), Vegetative State (VS), Minimally Conscious State (MCS), Stimulus-Onset Asynchrony (SOA)

3 Resum

Un dels majors reptes científics en l'àrea de neurociència és detectar alguns processos conscients en pacients amb desordres de consciència. En aquest Projecte de Final de Grau s'ha dissenyat un paradigma que avalua respostes cerebrals a violacions de regularitats temporals que poden ser tant locals en el temps o globals al llarg de varis segons. L'objectiu és ser capaços de diferenciar els pacients en estat vegetatiu d'aquells que es troben en mínima consciència o en un estat de consciència mitjançant senyals d'electroencefalografia (EEG). Una malla de sensors d'EEG amb 16 canals és usada per detectar els components de Potencials Relacionats Evocats (PRE) en resposta a estímuls auditoris. Els sons són presentats a alguns voluntaris a través d'una Interfície Gràfica de MATLAB Simulink on les senyals poden ser agafades, amplificades i enregistrades a temps real.

El paradigma auditori 'odd-ball' consisteix en series de cinc sons amb alguns sons diferents entre ells per tal de induir un canvi en els senyals del cervell de l'oient. Aquests canvis, anomenats Potencials Relacionats Evocats, són aïllats i observats per predir el futur diagnòstic de pacients amb desordres de consciència. Si persones sense la capacitat de interaccionar amb el seu voltant presenten alguns pics al seu potencial neuronal, és possible que despertin aviat.

Un model de Simulink de MATLAB ha sigut dissenyat i programat per a formar una via de comunicació entre els senyals biològics del cervell i l'ordenador. Sistemes d'adquisició de g.tec medical engineering han sigut també usats. Llavors, aquests senyals són processats per obtenir els gràfics resultants del voltatge en funció del temps.

S'ha requerit de gent voluntària per a realitzar l'experiment. Ha sigut possible registrar els senyals cerebrals de quatre persones sanes i només un pacient amb una malaltia cerebral s'ha presentat. No és possible confirmar que el sistema presentat en aquest projecte pugui predir la resposta dels pacients amb desordres de consciència d'acord amb el número de persones usades per testar. Tot i això, es pot establir un primer enfoc del patró que podrien seguir els senyals cerebrals en aquest tipus de pacients.

Paraules Clau: Pacients no Comunicants, Consciència, Violacions Globals, Violacions Locals, Sèrie Desviada, Sèrie Estàndard, Potencials Cerebrals, Processat de Senyal.

Abreviacions: Electroencefalograma (EEG), Potencials Relacionats Evocats (ERP), Estat Vegetatiu (VS), Estat de Mínima Consciència (MCS), Asincronia d'Inici d'Estímuls (SOA)

4 Introduction

Diagnose consciousness of a non-communicating patient is a difficult task for the health-professionals, and often they lack tools to make a decision about the future responses of the patient. The identification of reliable signatures of conscious processing goes beyond theoretical research and has critical practical implications to the clinic. In particular, detecting the signature is essential for patients with disorders of consciousness who, even during wakefulness, are seemingly unable to communicate. To better describe these disorders, a distinction has been introduced between the vegetative state (VS) and the minimally conscious state (MCS). Both exhibit similarly preserved arousal, but MCS patients show signs of intentional behaviour whereas VS patients remain largely unresponsive. Yet, medicine remain hard-pressed to decide whether a patient diagnosed as VS may still be conscious but unable to communicate [1].

From a clinical perspective, designing a simple neurophysiological test that could selectively monitor conscious-level processing and assess its integrity would be useful for patients suffering from consciousness disorders. It has been proved that the detection of neural events produced by an auditory stimulus offers a relevant step towards this goal [2].

An auditory paradigm is designed to evaluate the cerebral responses to violations of temporal regularities. Local violations due to the unexpected occurrence of a single deviant sound among a repeated train of standard sounds led to an early response in auditory cortex, the mismatch negativity (MMN) Event Related Potential (ERP) component, independent of attention. On the other hand, global violations, defined as the presentation of a rare and unexpected series of five sounds, led to a late and spatially distributed response that was only present when subjects were attentive and aware of the violations called P300 ERP component. In fact, it has been shown [3] that violations of the local regularity should elicit measurable ERPs in both conscious and nonconscious conditions, but violations of the global regularity should be detected only during conscious processing. Following this literature, with this method we could distinguish between VS and MCS patients and predict the possibilities to recover the consciousness.

In the present work, we explored the recordings obtained from five healthy people and one stroke person who present a consciousness disorder with the 'Local-Global' paradigm. The paradigm was implemented using a closed-loop system that provides a real-time feedback to the user with a 16 Electroencephalography (EEG) cap to probe the diagnostic reliability of the paradigm and explore the distinct ERP correlates of the violations of local and global regularities.

5 Motivation

The theme chosen for this project arises from my interest in signal processing and the need of this techniques in the field of neuroscience. Taking advantage of the starting of my curricular practices in an enterprise called g.tec medical engineering in where patients with some consciousness disorder or stroke were treated to neuro-rehabilitate through brain signal processing, I was decided to design an extra tool to interact with these people and try to help, in a long-term, patients which cannot communicate with their environment and do my final degree project about this topic.

After documenting, I was realized that it not possible to predict the chances of someone in a state of impaired consciousness, but there are some probabilities to detect small changes of brain regularities in response to auditory stimulus. In fact, there are some written paradigms that are thought to predict the diagnosis of a patient with some disorder of consciousness.

The idea of implementing a paradigm, easy to use for the physician and non-invasive, made me propose the challenge of carrying it out and test it with real people to see what happened with their brain. Also, the opportunity to dispose of the material from g.tec medical engineering, made the project easier and more viable.

6 Objectives

The overall objective of this Final Degree Project is the implementation of a protocol which allows the analysis of brain signals from people with disorders of consciousness through an auditory stimulation. The intention is to use a designed auditory protocol [3] to predict brain responses and be able to interpret them. A long-term objective could be described as the implantation of this kind of communication in hospitals, in order to enable an interaction with this non-communicating patients. The process takes some specific objectives, which must be performed in the following order:

1. Design the protocol according to the literature
2. Perform the algorithms to make a graphical interface to display the auditory paradigm
3. Make acquisitions of brain signals while the paradigm is executing via headphones
4. Process the recorded data
5. Interpret the results

7 State of art

It is important to take into account some aspects related to the neurophysiology and the methods through which the brain signals will be acquired. In this section, these characteristics will be explained for a better understanding of the methodology and results.

7.1 Disorders of Consciousness

Disorders of consciousness can occur if the parts of the brain involved with consciousness are damaged. There are some types of brain injuries which can be traumatic resulting from a severe head injury, non-traumatic which is caused by a health condition, and, finally, progressive brain damage because of diseases.

Consciousness is a state of being awake of one's self and surroundings [4] and its accurate and early diagnosis after the brain injury is very important. However, the currently assessment of awareness relies on physical responses being detected during examination. The main disorders of consciousness are:

- **Coma:** When a person doesn't show signs of being awake or aware. Normally, they lie with their eyes closed and doesn't respond to their environment, voices or pain. It has been known [5] that a coma usually lasts for less than 2 to 4 weeks, during which time a person may wake up or progress into a vegetative state or minimally conscious state.
- **Vegetative State (VS):** When a person is awake, but no signals of awareness are presented. They may open their eyes, wake up and fall asleep at regular intervals and can have basic reflexes such as blinking when they are startled by a loud noise or withdrawing their hands when it is squeezed hard. They are also able to regulate their heartbeat and breathing without assistance. If a person is in a vegetative state for a long time, it may be considered to be a continuing vegetative state or a permanent vegetative state depending on the brain injury. If a person is diagnosed as being in a permanent vegetative state, recovery is extremely unlikely but not impossible.
- **Minimally Conscious State (MCS):** When a person shows clear awareness, but it is minimal or inconsistent and it is diagnosed after a coma or vegetative state. They may have periods where they can communicate or respond to commands, such as moving a finger when asked. In some cases, a minimally conscious state is a stage on the route to recovery, but unfortunately in others it is permanent.

7.2 Brain Computer Interfaces (BCI)

Brain Computer Interfaces (BCI) constitute an alternative channel of communication between humans and environment allowing to control external software applications and devices as a response of brain activity [6]. The immediate goal of BCI research [7] is to provide communications capabilities to severely disabled people who has disorders of consciousness. It can consider as an artificial intelligence system that can recognize a certain set of patterns in brain signals following five consecutive stages (Figure 1). The first three stages, corresponding to signal acquisition, pre-processing or signal enhancement and feature extraction, are performed in this

project in order to provide the preliminary tools to complete the stage cycle of BCI system allowing, at last, the communication with the disabled patient. The signal acquisition stage captures the brain signals and may also perform noise reduction and artefact rejection. The pre-processing stage prepares the signals in a suitable form for further processing. The feature extraction stage identifies discriminative information in the brain signals that have been recorded.

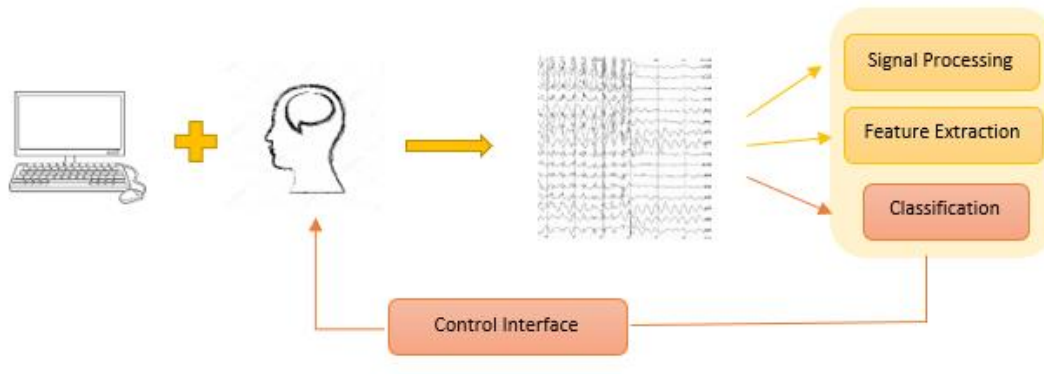

Figure 1: Scheme about a BCI process. A computer with the designed paradigm has been used to acquire EEG signals from patient's brain during trial. The signal has been pre-processed and feature extracted. A classification is done in order to perform a control interface which would allow a feedback with patient. Red square tasks have not been performed in this project. Then, only a processing and the feature extraction are obtained.

7.3 Electroencephalography (EEG)

The electroencephalography is the technology used in this project that allows to measure the outgoing signals of brain. It detects the electrical activity of the brain over time using electrodes placed on a scalp in a non-invasive manner. The scalp EEG signals can be recorded by different modes such as unipolar and bipolar modes. For this project, a unipolar mode scalp has been used in which voltage differences between all electrodes and a reference one is recorded, where a channel is formed by an electrode-reference pair.

The EEG recording system consists of electrodes, amplifiers, Analogic/Digital converters, and a recording device. The electrodes acquire the signal from the scalp, the amplifiers process the analog signal to enlarge the amplitude of the EEG signals so that the A/D converter can digitalize the signal in a more accurate way. Finally, the recording device, which in this case is a computer, stores and displays the data.

The purpose of using an electroencephalography for this project is based on the EEG studies [8], in where it is suggested that the detection of neural responses to violations of global regularities depends on the awareness of the subjects about the sequences. Then, a global discrimination signifies a conscious perception, mainly supported by the absence of evidence for a global regularity detection in patients in a vegetative state.

7.4 Event Related Potentials (ERPs)

It has been demonstrated [9] that, when subjects are assigned a task that requires them to determine to which of two possible categories each item in a series belongs, and one of the categories occurs rarely, these rare items will elicit an Event-Related brain Potentials (ERPs). This experimental arrangement is known as the 'oddball' paradigm. Also, some theories of consciousness [10] argue that, in the evoked brain potentials, early components correspond to unconscious processing stages, whereas late components are associated with conscious access.

The mentioned auditory protocol has the aim to produce stimulations in patient's brain in order to obtain direct responses from this and, succeeding, be able to interpret them. Event Related Potentials (ERP) can be defined here as the measured brain response to the auditory stimulus which is deduce from the Electroencephalography (Figure 2). As the EEG reflects thousands of simultaneously ongoing brain processes, is not usually to be able to visualize the response of a single stimulus in the recording of a single trial. Then, it is necessary that many trials have been conducted and averaging the result.

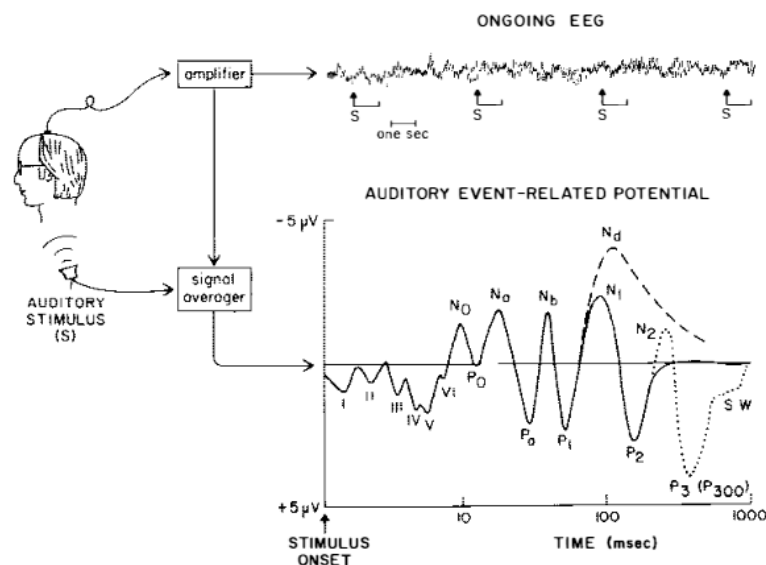

Figure 2: Idealized waveform of the computer-averaged auditory Event-Related Potential (ERP) to a brief sound. The ERP is generally too small to be detected in the ongoing EEG and requires computer averaging over many stimulus presentations to achieve adequate signal/noise ratios. Extracted from [10].

To go into detail about these ERPs, a distinction between the different components of the waveform among time obtained from the EEG signal recordings has been given:

- **Mismatch Negativity (MMN):** It is the earliest component that can be observed in an ERP trace. It can be defined as the negative component obtained by subtracting the event-related response to the standard event from the response to the deviant event [11]. The MMN is elicited in the presence of any discriminable change in some repetitive aspect of auditory stimulation and it can be detected even when the subject is not paying attention like during a comma or vegetative state.

LOCAL-GLOBAL PARADIGM: AUDITORY NEUROSTIMULATION

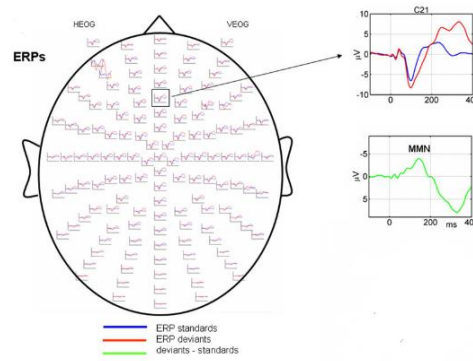

Figure 3: On the left it is presented a scalp map with the responses to standard and deviant tones. On the top right, the responses to the standard and deviant tones at specific channel are presented and, on the bottom right, the MMN difference wave obtained by subtracting ERP to standards from ERP to deviants is showed [11].

- **N100:** It is a negative evoked potential which appears between 80 and 120 milliseconds after the onset of a stimulus and it is weaker when stimuli are repetitive, and stronger when they are random. Then, it can help predict the probability of recovery of the individuals in coma.

As the MMN occurs at roughly the same time as N100, they may be confused. However, there are some differences such as they are generated in different locations and the MMN, unlike N100, may be elicited also by stimulus omissions.

- **P300:** It is a large positive waveform that reaches a maximum at approximately 300 milliseconds after stimulus onset (Figure 4). P300 is commonly elicited in signal-detection tasks [12] and, according to [13], the amplitude of the P300 varies directly with the relevance of the eliciting events and inversely with the probability of the stimuli. Then, the elicitation of this peak depends on the ability of the subjects to detect the rare event. This phenomenon suggests that it may be possible to allow the communication by persons who, as a result of injury or disease, has been deprived of expression.

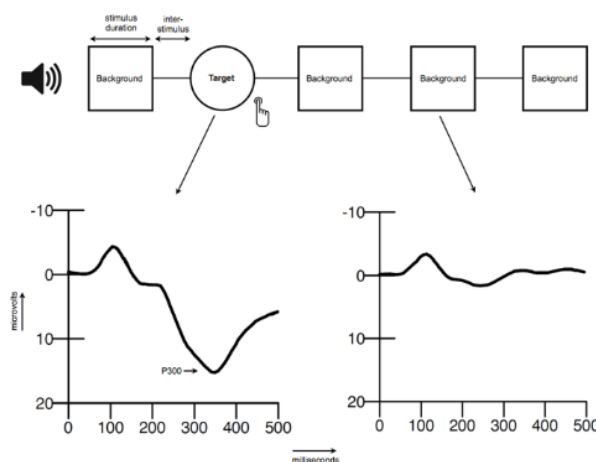

Figure 4: Schematic overview of the paradigm and an example of the extracted ERP. [12]

7.5 Amplification of brain signals

An amplifier is an electronic device or circuit which is used to increase the magnitude of the signal applied to its input. There are many forms of electronic circuits classed as amplifiers [14], but in this case an Operational Amplifier has been used. The parameter that measures how much an amplifier amplifies the input signal is called Gain, which is measured by the output signal divided by the input signal (Figure 5).

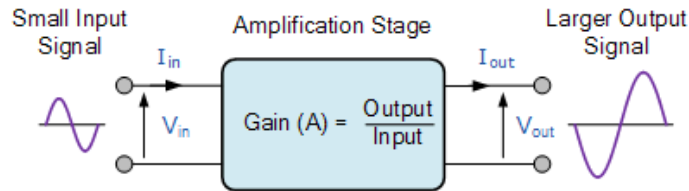

Figure 5: Scheme of an amplifier. The Gain measures how much it amplifies the signal [14].

The operational amplifier (Figure 6) used in this project consists in a differential input and a single-ended output. It is connected into our computer via USB as the output, and at the same time, into the EEG system acquisition as the input. Their mission is to take the signals of the electrode-reference pairs from EEG cap and amplify these to pass them through the model.

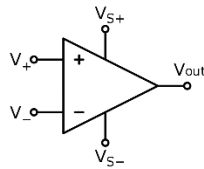

Figure 6: Circuit diagram symbol for an op-amp [15].

7.6 Signal Processing Methods

Control by means of changes in electrical activity of the brain is possible by the procedures employed in EEG Signal Processing [6]. The specific operations to which the signal is subjected are designed to identify the characteristic changes in the continuous EEG recording, which corresponds to the features extraction, and to match the fragments identified with specific mental activities defined as features classification.

Signal Processing methods must take into account the individual variations of EEG activity in representation in space, time and frequency range [6], aiming to extract discriminative features from EEG channels in order to prepare the data for the decision unit in where, in the case of Brain Computer Interfaces (BCI), has the purpose of classification, decision-making, and passing the decisions to external devices outputting the intention of the subject [16]. In this project, a non-invasive device has been used to record the EEG signals generating some noise. Then, an additional signal processing tasks has been done to compensate these effects.

There are several techniques [17] to perform digital signal processing. These techniques depend on the type of analysis and feature extraction is wanted to accomplish. A brief explanation of the ones used for this project has been done.

7.6.1 Filtering

The process of filtering consists in remove the unwanted components or features from signal. There are various types of filters such as High pass (HP), Low pass (LP), Band stop (BS), Band pass (BP), and Notch filters. A Notch filter and a Band pass filter have been used with the following purposes:

- **Notch filter.** It is essentially a band stop filter with a very narrow stop band and two pass bands. The amplitude response, $H_1(\omega)$, of a typical notch filter (Figure 7) is characterized by a notch frequency ω_d (radians) and -3 dB Rejection Band Width (RBW). For an ideal notch filter, this RBW should be zero, the pass magnitude should be unity and the attenuation at the notch frequency should be infinite [18].

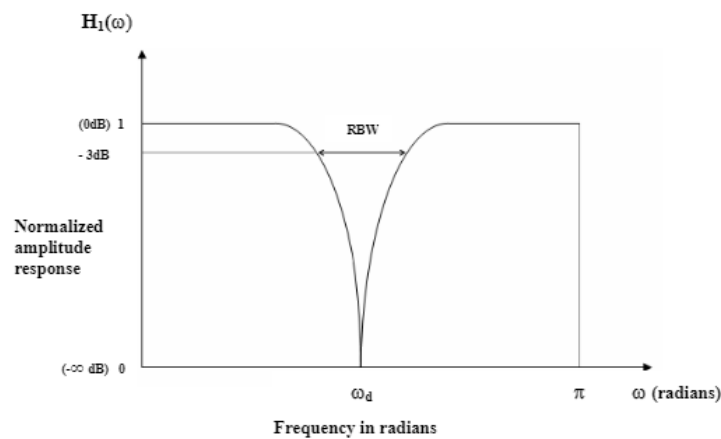

Figure 7: The normalized amplitude response $H_1(\omega)$ of the notch filter. Adapted from [18].

- **Band Pass filter (BP).** Since there are no ideal signal generators or power amplifiers, the amplitude signal will contain not only the signal of the fixed excitation frequency but also different frequency components [19]. The BP filter permits the pass of frequencies within a certain range and rejects or attenuates frequencies outside this range. It comprises a HP filter and a LP filter and it is realized by cascading the circuits for HP filter and LP filter [Figure 8].

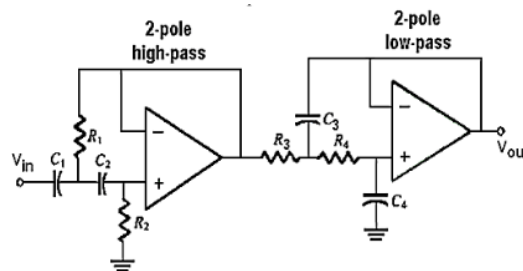

Figure 8: Fourth-order Butterworth active Band Pass Filter schematic diagram with the combinations of a 2-pole HP filter and 2-pole LP filter cascaded together [19].

The frequency response of the Butterworth Filter approximation function is also often referred to as “maximally flat” response because the pass band is designed to have a frequency response which is as flat as mathematically possible from 0Hz (DC) until the cut-off frequency at -3dB with no ripples. The magnitude response of a BP filter is shown in Figure 9:

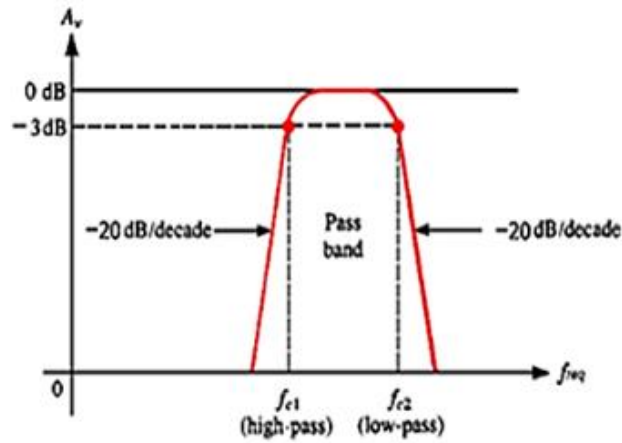

Figure 9: Band Pass Filter Magnitude Response [19]

In where the response in this project-case is determined by a 4th order of a Butterworth filter. The higher the Butterworth filter order, the higher the number of cascaded stages there are within the filter design, and the closer the filter becomes to the ideal “brick wall” response (Figure 10).

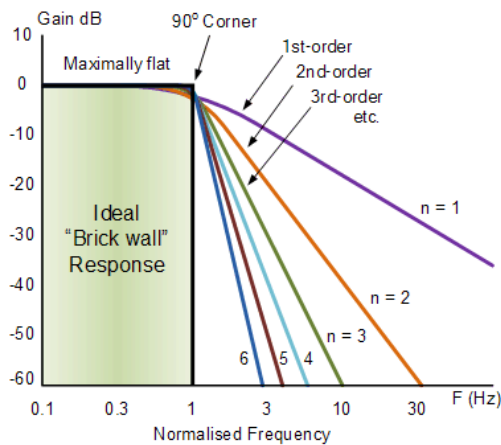

Figure 10: Responses of BP filter depending on the order of Butterworth filter.

7.6.2 Artefact Rejection

When an EEG recording is performing, two types of artefacts can be distinguished, depending on the environment or the patient body [20]. Technical artefacts such as power line interference, impedance fluctuation and wire movement, superimpose their energy observed in EEG signals because of faults in setting conditions. These can be precluded from easy ways (Figure 11), like detaching a charging AC adapter from the recording device, carefully attaching electrodes to the scalp, and using appropriated electrode wires or adhesive tapes to stabilize wires.

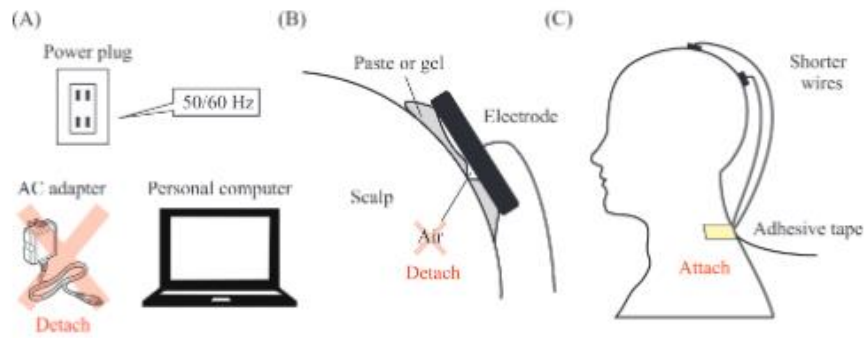

Figure 11: Ways of precluding technical artefacts. (A) Power line interface. (B) Impedance fluctuation. (C) Wire movement. Extracted from [20].

The second type are biological artefacts, which are the ones rejected after signal acquisition by signal processing, are defined as discharged potentials of internal organs and they diffuse their energy over the head and reach each electrode attaching on the surface of the scalp observed in EEG signal. These come from muscular movements, heart rate and eyes movements [Figure 12]. Then, if contaminated epochs are found in visual or quantitative analysis, they have been ignored. In this project-case, amplitudes greater or minor than $100\mu\text{V}$ are rejected.

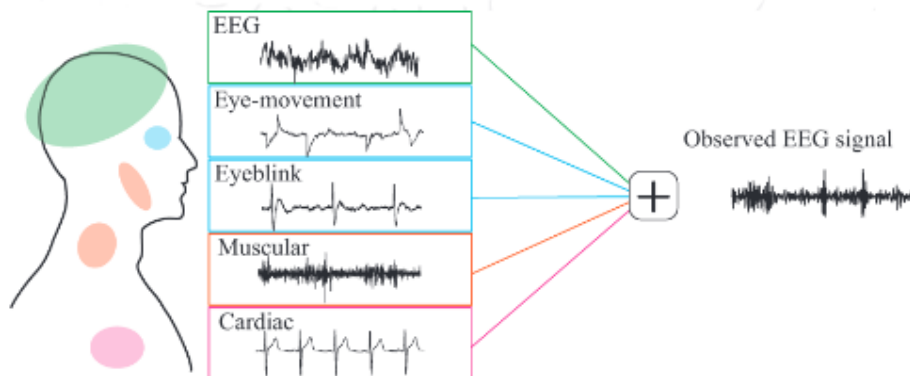

Figure 12: Example of an observed EEG signal including biological artefacts. Extracted from [20].

7.7 Statistics

Visually, an estimate can be made between the difference of two signals after its processing, but usually this should not be an accurate method. A t-test has been performed to compare the two averaged EEG signals. It allows to know if these differences could have happened by chance and it can be defined as a ratio between the difference between two paired samples. The larger the t-score, the more difference there is between the values. Also, every t-value has a p-value to go with it. A p-value is the probability that the results from the sample data occurred by chance, then low p-values are good since it means that there is a low probability that it happens casually.

There are many types of t-test [21], but paired t-tests have been chosen since it compares means from the same group at different times and it is always done when a t-test on dependent samples is run, like this project-case. MATLAB `ttest2` function has been used to calculate automatically if the paired samples of data differ more than a 5%. Manually, the procedure would be the following:

$$t = \frac{(\sum D)/N}{\sqrt{\frac{\sum D^2 - \frac{(\sum D)^2}{N}}{(N-1)(N)}}$$

Formula 1: Formula to calculate the t-score

In where $\sum D$ is the sum of the differences between two samples, $\sum D^2$ is the squared differences, and $(\sum D)^2$ is the squared of the sum of the difference. Then, the degrees of freedom have been ascertained subtracting 1 from the total sample size and the p-value is extracted using these degrees of freedom and a specified value of alpha (maximum percentage of variation between data). Finally, if the calculated t-value is greater than the value at an alpha level, the two samples are defined as a significantly different.

8 Materials and Methods

8.1 Auditory stimulation

We used the local-global protocol [3] which consists in series of five sounds of 50ms each one and 150ms SOA between them. Each sound was composed of three superimposed sinusoidal tones (either a low-pitched sound with 350, 700 and 1400 Hz tones, hereafter sound A; or a high-pitched sound with 500, 1000 and 2000 Hz tones, hereafter sound B. Tones were prepared with 7ms rise and 7ms fall times. Four different series of sounds were used, two of them using the same five sounds (AAAAA or BBBBB); and the other two with the final sound swapped (either AAAAB or BBBBA). Series of sounds were separated by an interval of 750ms (from the onset of the fifth sound until the onset of the first sound of the next series). The blocks were designed to contain series with a deviant sound in the end, either as an infrequent stimulus (block type 1: 80% AAAAA/ 20% AAAAB; block type 2: 80% BBBBB/ 20% BBBBA); or as a frequent stimulus (block type 3: 80% AAAAB/ 20% AAAAA; block type 4: 80% BBBBA/ 20% BBBBB).

Each block started with 20 series of sounds of the frequent type in order to establish the global regularity with 100% regular stimuli, before switching to the block with 80% frequent and 20% rare series. In each block the number of infrequent trials were 25 (appearing randomly among frequent trials), in a total of 120 series including the ones for the global regularity.

The model was presented via headphones to the subjects. They heard blocks with the order and with a number of times that the physician had chosen. Each block takes a duration of 3-4 min.

Local regularity is defined by the detection of the deviant series (which will be the one with the fifth different sound) in a block, and the global regularity is defined by the frequency of the different series of all blocks together (which can be the one with the fifth different sound or the one with the same five sounds depending on the type of block). Then, the conscious subjects should have to distinguish a deviant sound in every block, called local regularity, and also if there are a lot of standard series and some different series in the set of them, defined as global regularity.

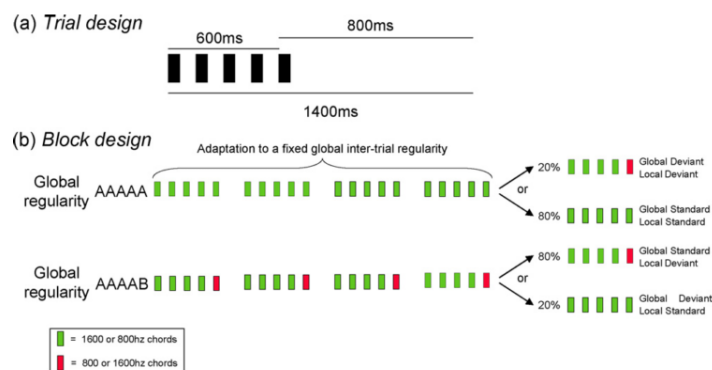

Figure 13: (a) On each trial, five complex sounds of 50ms duration each were presented with a fixed stimulus onset asynchrony of 150ms between sounds. Four different types of series of sounds were used, two of them with the last sound swapped (AAAAB, BBBBA) and the other two with the same sound in all trial (AAAAA, BBBBB). (b) Each block started with 20 frequent series of sounds to establish the global regularity before delivering the first infrequent global deviant stimulus. Adapted from [3]

8.2 Hardware

All materials that have been used for this project have been provided from g.tec medical engineering, as well as their installations to make possible the correct acquisition of the data, since a specific environment is needed. In detail, a set of cables to establish the connections, devices, computers and additional material (such as a syringe to put the gel) are necessary for the procedure. Then, the most important devices are going to be explained.

8.2.1 EEG cap and Electrode System

Signals has been acquired through a scalp placed over the head of the patient. It consists in a set of electrodes distributed along the scalp in order to record the activity of the brain meanwhile the auditory paradigm is performed. The scalp used in this project is a g.GAMMAcap. It is flexible for high-density electrode placement with 74 labelled standard positions (10-10/extended 10-20 system) plus 86 additional intermediate positions which has been fixed onto the head with a chest belt.



Figure 14: Scalp called g.GAMMAcap in where the electrodes are placed.

A g.SCARABEO electrode system is used to place into the g.GAMMAcap. This is a compact active electrode for high-density EEG and its function is to record the signals from brain using a conductive gel. These electrodes are usually made of silver chloride (AgCl).

The Electrode-scalp contact impedance should be between 1 k Ω and 10 k Ω to record an accurate signal [7]. The electrode-tissue interface is not only resistive but also capacitive and it therefore behaves as a low pass filter. The impedance depends on several factors, such as the interface layer, electrode surface area and temperature. EEG gel creates a conductive path between the skin and each electrode that reduces the impedance.

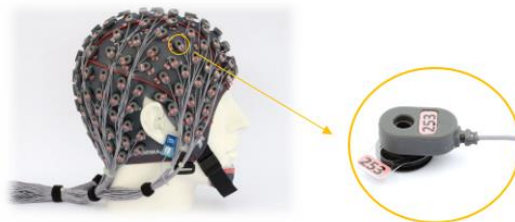

Figure 15: The electrode system called g.SCARABEO which contains the electrodes placed in the scalp.

8.2.2 USB amp

After signals have been acquired, it must pass through an amplifier in order to analyse them. The amplifier used in this project is the g.USBamp. It is USB enabled and comes with 16 simultaneously sampled bio-signal channels of 24 bits. Four independent grounds guarantee no interference during the recordings. The amplifier has an input range of $\pm 250\text{mV}$, which allows recording of DC signals without saturation [22]. It can work both in passive and active electrodes, consisting of 8 digital trigger inputs and 4 digital outputs. Also, it includes an internal digital bandpass and notch filters, built-in calibration unit and impedance checking.

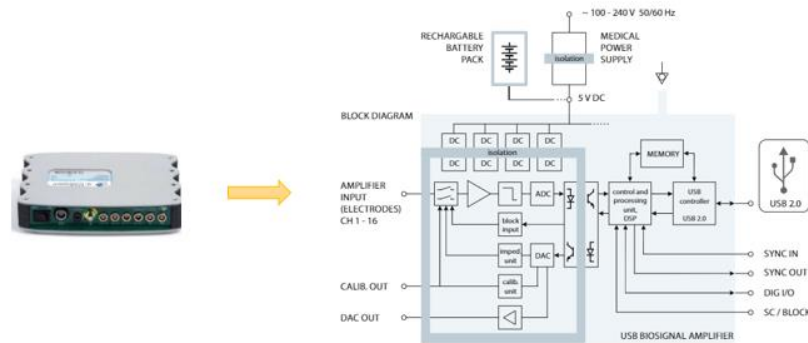

Figure 16: USBamp internal architecture. The control and processing units acts as a bridge between the computer and the EEG acquisition system. A power supply has been used to provide the operating power, an isolated module takes the EEG signal, amplifies it and perform the conversion to digital data to be read by the computer.

8.2.3 TRIGGER box

The g.TRIGbox is a device to generate trigger pulses from various sensors or input signals. Input and output lines are isolated from each other. The trigger outputs have been connected to inputs of the g.USBamp. Thus, the TRIGGER box provides an exact detection and recording of the stimulation. The headphones are also connected to the trigger, in order to synchronize the displaying of sounds and the acquisition.



Figure 17: g.TRIGbox used to synchronize sounds and EEG acquisition.

8.3 Assembly

Once materials have been described, the assembly which allows the acquisition of the EEG signals has been presented:

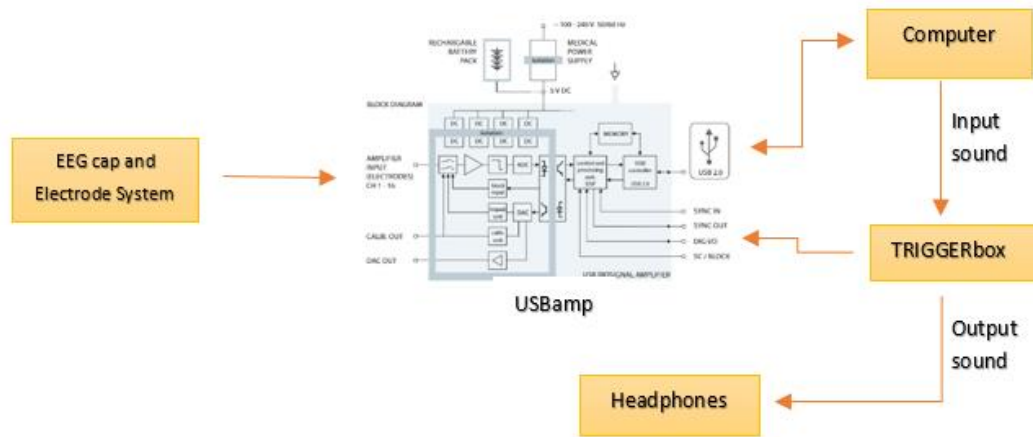

Figure 18: Architecture of the project with the materials and connections to make the acquisitions.

The EEG signal coming from the EEG cap and Electrode System enters to the amplifier. In there, the computer sends the parameters to perform the acquisition with the specified manner previously defined and, at the same time, the amplifier sends the real-time acquisition to the computer. Also, the TRIGGER box is connected to the computer to take the sounds files and it transfers its activation to the amplifier and to the headphones in order to synchronize the signal acquisition and the sound plots.

8.4 Software

Following the Local-Global paradigm literature which have been explained before, algorithms have been performed to create a model displaying the auditory protocol and integrating the inputs and outputs of the devices that have been used. Also, a post-processing of signal after the acquisition has been done to obtain the graphical results. All scripts have been programmed with MATLAB R2017b and Simulink from MATLAB. A g.BSanalyse application toolbox integrated in MATLAB has been used to interact with the devices.

8.4.1 System-Function

System-functions are created in order to extend the capabilities of the Simulink environment. It is a computer language description of a Simulink block written in MATLAB linking subroutines that can be automatically loaded and executed. S-Functions use a syntax called the S-function API that enables to interact with Simulink engine. The mathematics of Simulink Blocks consist of a set of inputs, a set of states and set of outputs (Formula 2), where the outputs are a function of the simulation time, the inputs and the states. The execution of a Simulink model proceeds in stages defined in the S-function algorithm [23].

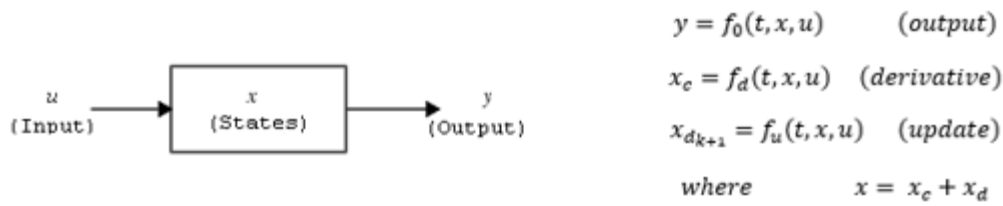

Formula 2: On the left, the mathematics of Simulink Blocks and on the right, the mathematical relationships between the inputs, outputs, and the states. Adapted from [23]

An S-function is created for this project in order to incorporate library blocks into the model, propagate signal widths, data types and sample times. Some parameters are also included for the physician to personalize the trial like the block execution order, randomize it or pause the model manually when they want. The engine then enters in a simulation loop, where each pass through the loop is referred to as a simulation step. During each simulation step, the engine executes each block in the model determined previously. For each block, the engine invokes functions that compute the block states, derivatives and outputs for the current sample time.

Definition of S-function

The architecture of the used S-function for this project consists in zero inputs and three outputs that takes the EEG signal, the sound files and the number of block respectively. Then, the local-global paradigm is created and assigned into variables in a suitable manner to enable its reading by the model. Finally, the defined variables together with the parameters selected by the user in the parameter dialog block are used in order to define the paradigm and present it to the patient through headphones. The EEG acquisition in real time during the execution of paradigm has been saved to be subsequently analysed.

An S-function comprises a set of S-function *callback methods* that perform tasks required at each simulation stage. During simulation of a model, at each simulation stage, Simulink calls the appropriate methods for each S-Function block in the model. Tasks performed by S-function methods include:

- **Setup(block):** Specify the number of parameters that this S-function supports and configure the block's input and output ports specifying the number and the dimensions of them. Also, the block-based sample times are defined in this function.
- **DoPostPropSetup(block):** Specify the sizes of the work vectors, which are the ones that the S-function needs to store global data and to create run-time parameters, and it is based on the number and sizes of inputs and outputs and on the number of sample times.
- **InitializeConditions(block):** The Simulink engine invokes this function at the beginning of a simulation and every time the system restarts execution. It initializes the continuous and discrete states using *Dwork* run-time object methods to access to them.
- **Output(block):** The Simulink engine invokes this required method at each simulation step. It calculates the outputs of the S-function at the current time step and store the results in the *OutputPort(1)* as it is above mentioned.

8.4.2 Model generator

A Simulink is a tool from MATLAB which allows to create a graphic interface with a customizable block libraries and solvers for modelling and simulating dynamic systems. This graphic editor has been used to create the model to run the paradigm. It will be created to allow its usage by health professionals to make recordings from patients and store their results.

MATLAB algorithms have been generated to simulate the designed Local Global auditory protocol. The architecture consists in different blocks which every one of them takes a role in the set. The sounds have been generated as the previous described order due to a block which monitor the timing and the procedure of the model. The signal has been recorded in real time and it has passed through an amplifier block. Then the data is converted from analogic to digital format and finally it can be visualized in a real-time and saved when the model ends. Below, a more detailed information about each block is presented:

- **Soundfile ID:** With this block, sound files can be selected from the computer being the ones which will correspond to tones that the model uses to display. These are the sound A and sound B previously mentioned in the Auditory Stimulation section.

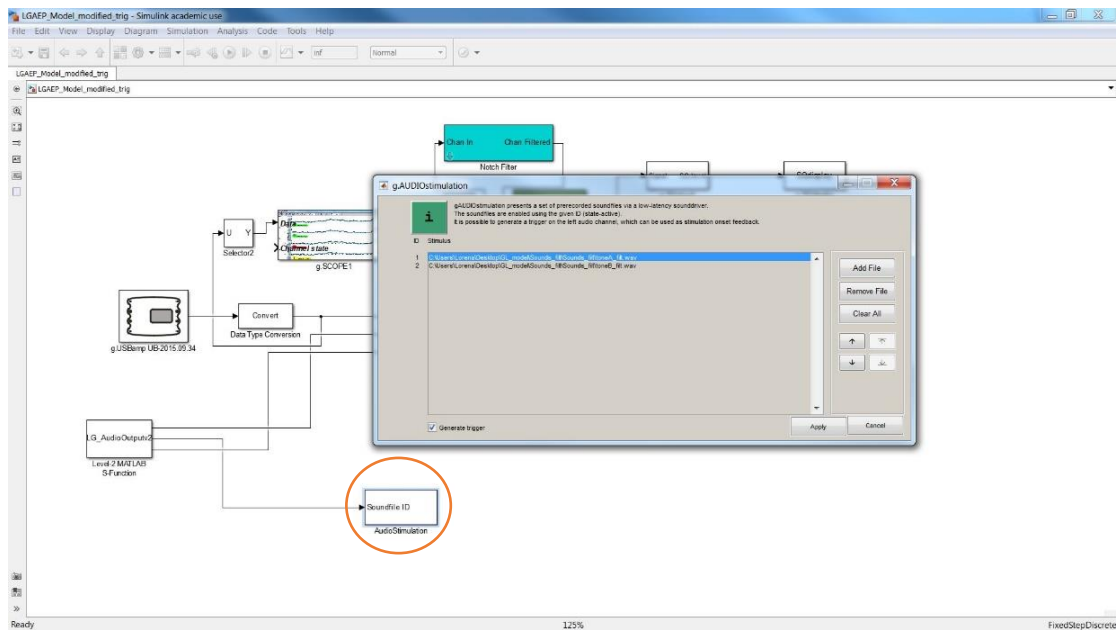

Figure 19: Screenshot of the graphical interface from Simulink with the *Soundfile ID* block selected.

- **System-function:** This is the block in which it is described the procedure of auditory protocol. It allows sharing the same System object in MATLAB and Simulink and, at the same time, providing an integration of the other blocks of Simulink environment. In this model architecture, the S-Function pick up the sounds from *Soundfile ID* and make them sound in the order that the paradigm marks. Also, the physician can select the parameters for the block thanks to an instance created in the model. With this, it is possible to define the number of repetitions of each type block, specify the blocks that is wanted to be displayed and the order they will be presented to the patient and, finally, if the pause will be applied automatically or not.

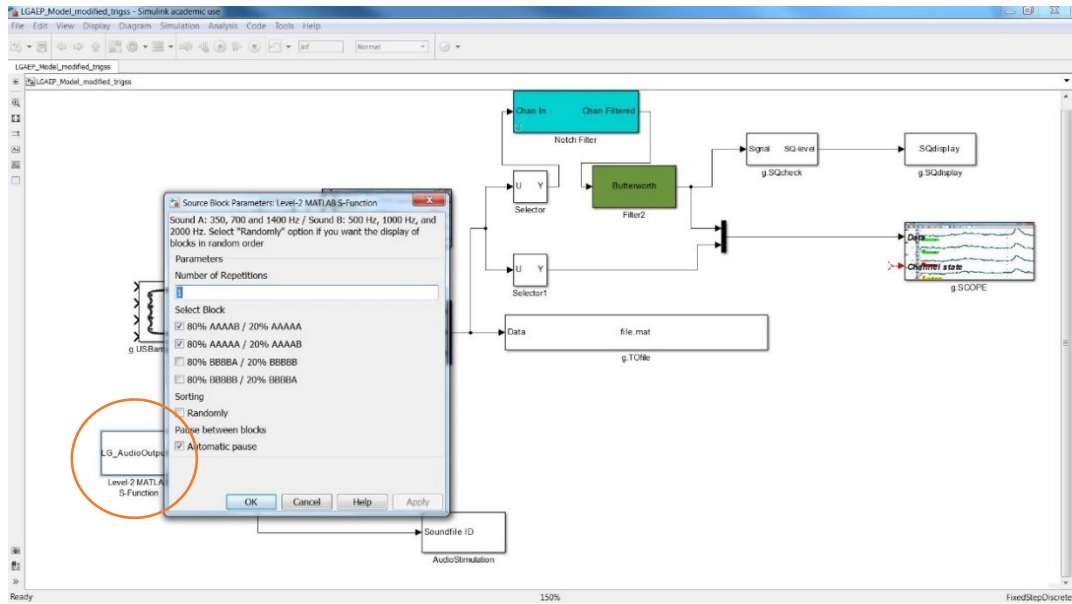

Figure 20: Screenshot of the graphical interface from Simulink with the *System Function* block selected.

- g.USB amp:** The amplifier is used to pass through it the signal coming from the EEG cap in a real time. In this block, it is possible to specify the sampling frequency, the channels of interest and their settings such as the polarity and the types of filters.

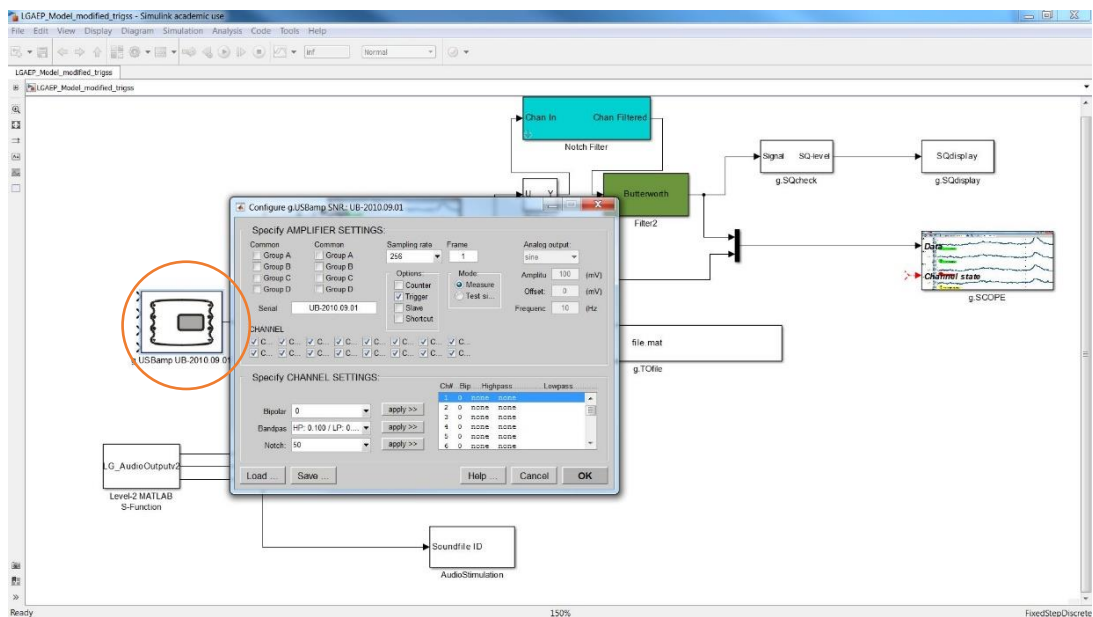

Figure 21: Screenshot of the graphical interface from Simulink with the *g.USBamp* block selected.

- g.TOfile:** After the data has been recorded, amplified and converted, it is saved into a folder thanks to this block. This allows to specify the data size and storage them even if a memory limitation in MATLAB will occur.

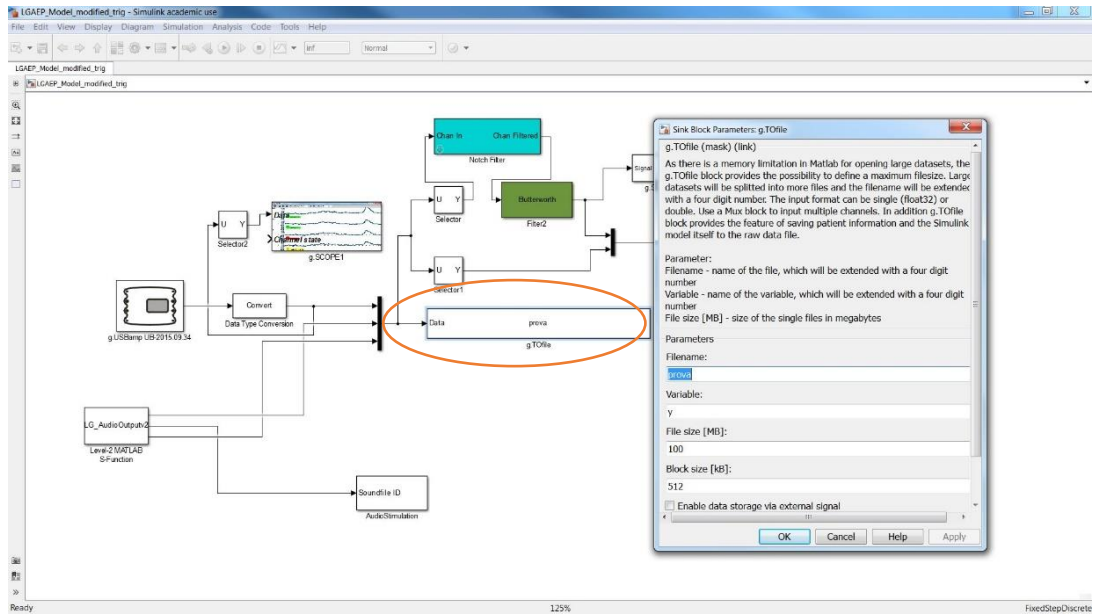

Figure 22: Screenshot of the graphical interface from Simulink with the *g.TOfFile* block selected.

- Simulink environment:** In the upper bar of graphical interface from Simulink there are the buttons to run the model, pause it manually when the health professional wants, resume again later or stop it. Also, a *g.SCOPE* is provided in order to visualize the signal of each channel in a real time meanwhile the test is performing. To the right of the Simulink environment window there are a set of blocks that are not relevant to model execution. They allow to check that all channels are recording properly the signal coming from EEG cap. Also, another *g.SCOPE* with a Butterworth filter is providing in order to obtain a better visualization of the signal. As it can be seen, the output of these blocks is not saved anywhere.

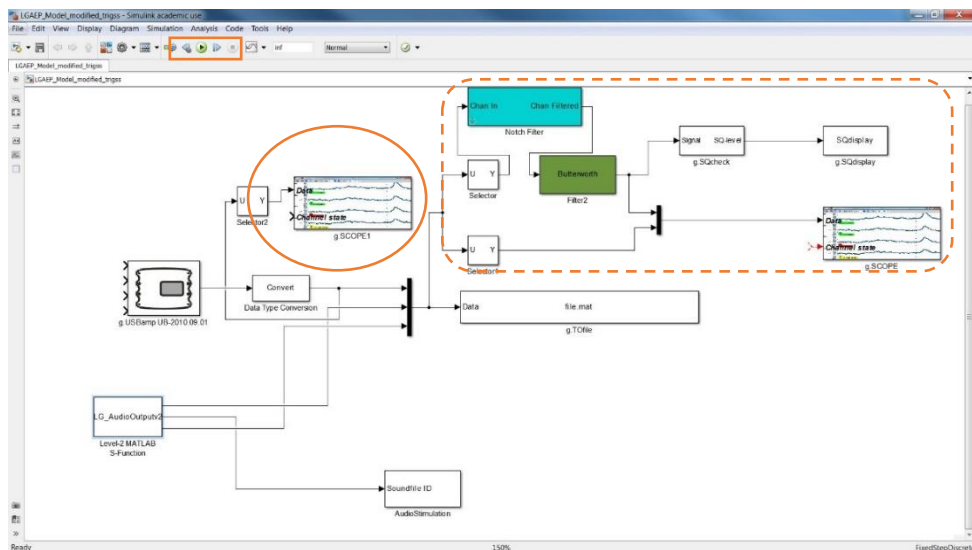

Figure 23: Screenshot of the graphical interface from Simulink.

8.4.3 Signal Processing and Features Extraction

Once EEG signals have been collected during the experiment, they must be processed in order to obtain an optimal visualization to analyse the results.

This signal processing consists in a filtering and an artefact rejection, followed by an averaging of all channels and the cut of signals in the precise moments when the ERP should be observed.

The resultant matrix obtained from the model is a $(20 \times n)$ matrix (Annex 1), where n depends on the duration of the acquisition and the sampling frequency. First row corresponds to the time of acquisition according to the sampling frequency; next 16 channels correspond to the EEG cap channels connected to the amplifier, the next two correspond to the trigger plot and trigger generated by the model respectively; and finally, the last row shows the number of current block. The process can be defined with three differentiated steps:

a) Filter the data.

After taking the channels that correspond to the EEG signal, they have been passed through two different filter types (Figure 24). The first one is a Notch filter in a frequency of 50Hz. It is used to remove the frequencies corresponding to noise. The second one is a bandpass filter between frequencies of 0.1 Hz and 20Hz. It ensures that it is only taken the frequency range of interest.

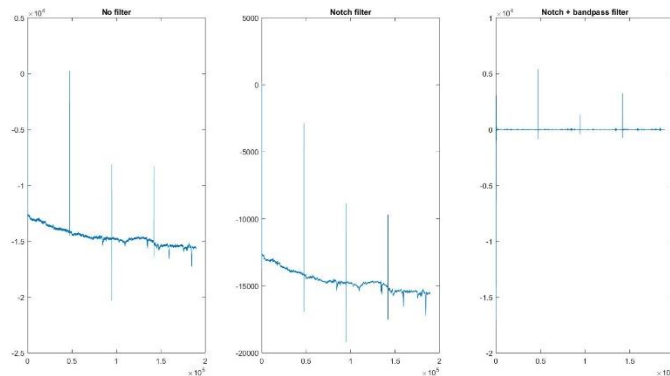

Figure 24: On the left, the result of applying a Notch Filter in the CPZ channel of EEG signal. In the middle, results of applying a Band Pass filter with a Butterworth response of 4th order in the CPZ channel of EEG signal. On the right, the resulting EEG signal of CPZ electrode as a response of applying both filters. [Graphics obtained from own recordings].

b) Cut signals according to Local-Global paradigm architecture.

Depending on the pre-definition of the model that the physician has been chosen, the block types and their order will be different. Then, some steps are differentiated:

- **Find the start and the end position of the trigger** since it is activated with each sound. When a trial is performed, the trigger-box plots are configured to be displayed in one of the channel of the EEG recording. Then, a row of the resulting matrix corresponding to this channel has been taken to know at what precise moments of the trial it has been activated. This pre-processing allows to

select the EEG signal which corresponds to two types of sounds, as well as to identify the series of each block.

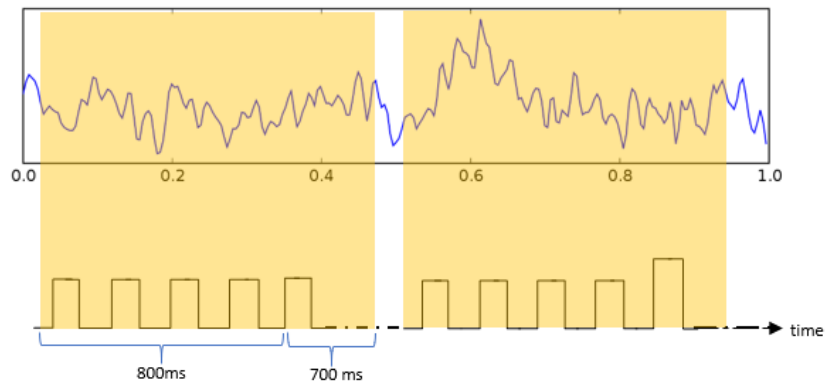

Figure 25: To the top, an example of EEG signal acquisition is presented. To the bottom, an example of the activation of trigger-box plots is shown. When the trigger is activated, a sound is heard, and it is drawn in the channel as oscillations. If the oscillation takes a major amplitude, it corresponds to sound B, otherwise corresponds to sound A. The fragments of EEG signals which have been taken are in range of $800\text{ms} < (\text{the onset of the fifth sound}) < 700\text{ms}$.

- **Check the block type.** The S-function block from Simulink model has been also configured to display the number of block in one of the output channels. Then, a resulting row with blocks that have been executed during the trial and their corresponding EEG signals can be subtracted.
- **Solve acquisition problems.** Due to the real-time acquisition, some unwanted events with the signal recording can occur. The first problem comes from the trigger-box, since it is possible that some trigger plots are missing between series. It is important that the data corresponding to these fragments should be omitted to ensure that the next fragments will be taken correctly. Another problem is that, for unknown reasons, when the model is paused manually and then restarted again, the channel corresponding to the trigger draws an oscillation. This should also be removed in order to prevent the addition of fake EEG signal fragment to the analysis of the results. The method used to identify these false plots is configured in the S-function block of the Simulink model, in where the channel corresponding to block's number displays a -1 when this event happens.
- **Baseline and artefact correction.** The baseline correction consists in take the mean of the samples corresponding to 800 milliseconds before the onset of the fifth sound and, then, subtract these value from each of the real sample value in these 800ms fragments. This correction ensures that the obtained data before the Evoked Potentials do not shift or drift away from the baseline [24]. In other site, to perform an artefact correction, as it is defined in *State of Art* section, a threshold of $100\mu\text{V}$ is applied to the data to remove the samples corresponding to artefacts.

In addition, a MATLAB tool called g.BSanalyze is used to perform some signal processing techniques. It is a multimodal offline bio-signal processing and analysis with MATLAB and Simulink including functions for defining electrode montages, spatial or temporal filter designs, artefact treatment, band power analysis, etc. Its processing capabilities allow users to extract relevant features of their multimodal data and to define useful parameters for post-processing. These parameters can be used directly with g.BSanalyze’s classification tools to assign distinct classes to data.

Once signal is pre-processed with the described techniques, the rows of the resultant acquisition matrix corresponding to the EEG are isolated in order to visualize the Evoked Related Potentials after the last sound of each series. Series without some trigger plot are removed. The ranges corresponding to from 800ms before the onset of the fifth sound to 700ms after, are taken to observe the signal shape (Figure 26). Then, the data frames are divided in groups (Figure 26) depending on the series of sounds: if the series is BBBB or AAAA it will be a *local-standard* series and in the case of BBBBA or AAAAB it will be considered as a *local-deviant* series. At the same time, one series will be a *global-standard* or a *global-deviant*, depending on their frequency of appearing in each block, since blocks 1 and 3 have more local-deviant series than local-standard and blocks 2 and 4 have more local-standard series than local-deviant series.

	Global-Standard	Global-Deviant	Local-Standard	Local-Deviant
Block 1	AAAAB	AAAAA	AAAAA	AAAAB
Block 2	AAAAA	AAAAB	AAAAA	AAAAB
Block 3	BBBBBA	BBBBB	BBBBB	BBBBBA
Block 4	BBBBB	BBBBBA	BBBBBA	BBBBB

Figure 26: Division of the different types of series. Global-Standards correspond to series with the same five sounds, being A or B. Local-Deviants correspond to series with the fifth sound different. Then, depending on block type and the percentage of repetition of each type of series in it, the series can be Global-Standards or Global-Deviants. Blocks 1 and 3, in which the series with a different sound in the fifth position appears at 80%, BBBB series in the case of block 1 and AAAA series in the case of block 3 will be the Global-Deviant ones. On the other hand, blocks 2 and 4 have an 80% of series with the five equal tones, then BBBBA in block 2 and AAAAB in block 4 will be considered as a Global-Deviant series.

Finally, data of all EEG channels, both together and each one separately, corresponding to Global-Standards and Global-Deviants are averaged in order to obtain a graphical comparison between all the global effects. The same procedure is done with Local-standards and Local-deviants to compare the local effects. Also, the mismatch negativity is represented doing the subtraction between two signals of both global and local effects.

8.5 Signal Acquisition

8.5.1 Subjects

During this evaluation, five healthy subjects and one subject with a brain injured (age range = 20 - 35; sex-ratio (male:female) = (2:1)) were presented with the 'Local Global' auditory protocol, which is designed to elicit event-related potentials that provide us information to help assess patients' state of consciousness in future studies. More than one test for each subject has recorded requesting a counting task and also a mind-wander state.

All subjects have been informed about the protocol. Also, an informed consent has been read and signed by each of them before starting the trial in where there is explained the methods and the conditions they are going to be exposed. The privacy policy has been applied with their confidential data.

8.5.2 EEG recordings

EEG recordings were sampled at 256 Hz with a 16 EEG channel cap (g.SCARABEO, g.tec medical engineering GmbH) whose electrodes are placed over the sensorimotor cortex following the 10/10 international system of scalp layout: FC5, FC1, FCz, FC2, FC6, C5, C3, C1, Cz, C2, C4, C6, CP5, CP1, CPz, CP2, CP6 (Figure 27). The FPZ electrode is connected to the ground and a reference electrode is placed on the right earlobe. The EEG cap is connected to an amplifier (g.USBamp, g.tec medical engineering GmbH), which is connected, in one hand directly via USB in the PC/notebook to run the model with the paradigm, and in the other hand in the EEG cap for data recording. Also, a multimodal trigger system (g.TRIGbox, g.tec medical engineering GmbH) is connected to the amplifier in order to generate the trigger pulses with a precision of less than a millisecond.

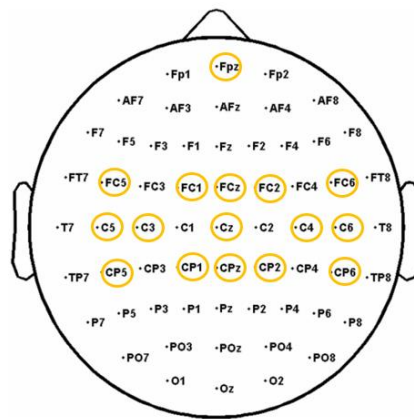

Figure 27: 10-10 EEG electrode positions for the placement of the electrodes above the head marked by a yellow circle the used ones. These electrodes (channels) show the activities of different brain areas.

A model was configured by the physician taking the blocks that they want to display, the order of them during the paradigm and select an automatic or manual pause. Also, a previous explanation of the instructions to perform with a correct manner the Local-Global paradigm has been done for the patient. They must be advertised that a repetitive series of five sounds are going to be displayed via headphones. These series will consist in the combination of two tones sound like

'beep' and 'boop'. All series are formed by the same five sounds or by four same sounds with the last one different. At the same time, these series will be organized in blocks, in where the combination of sounds and their appearing frequency are different. At the beginning of each block, it will be listened some same series repeating unchanged. It is also requested that it is not necessary to count the number of different series of the blocks, but they have to relax and only listen.

Finally, the physician will help or assist to the patient to put the headphones and start the trial. EEG recordings can be visualized at real time during the acquisition through the g.SCOPE block of the Simulink model. When the model ends, signal acquisition will be save into the computer to be pre-processed and, finally, perform the analysis.

9 Results

9.1 Pre-processing data

As it has been explained, EEGs were sampled at 256Hz, band-pass filtered from 0.5 to 20Hz and artefact removed ($\pm 100\mu\text{V}$). A baseline correction was applied over the 800ms window before fifth sound onset. Series with one or more missing sounds are removed. Also, series with an error in the trigger box plot are eliminated.

All trials were segmented from -800ms to +700ms relative to the onset of the fifth sound to analyse the global and local violations.

To analyse the global violations, we have to consider the standard and deviant series of the experiment, which will depend on the block number. In the case of local violations, we have considered the series with a different sound at the end as deviant and the ones with same five sounds as standard. The data corresponding to the trials have been set according to the trigger plots.

9.2 t-test based statistics

Matlab R2015a were used to compute sample-by-sample paired t-tests. Significance threshold was defined by a criterion of $p \leq 0.05$. ERPs average has been done across trials in order to compare EEG data responses given from deviant and standard sounds.

9.3 Auditory model of neurostimulation

A Simulink model has been designed and created with the auditory paradigm with the objective of elicit changes in brain potential. A Simulink environment from MATLAB has been used to adapt the designed blocks displaying the sounds and performing the acquisitions at real time. After following the literature and with some adaptations explained throughout the work, the created Graphical Interface has worked properly, and it has been possible to acquire the brain signals during the auditory test to be later analysed.

9.4 Event-Related Potentials

We analysed ERP data by focusing on basically two electrophysiological effects as described above: global effects and local effects.

9.4.1 Global Effects

We first examined brain responses from a stroke patient to violations of global regularity of both all channels separately (Annex 2) and averaging all channels together (Figure 28), by comparing the global standard trials from global deviant trial. This regularity is defined by the capacity to detect that there are some series during the trial which appears more frequent than the others. First negativities of the averaging signal which corresponds to the global deviant trials are presented at approximately 50ms and 100ms. This can be traduced as a N100 ERP evoked by the presence of an oddball during the execution of the blocks. However, it is not observed the P300 ERP corresponding to the detection of the global regularity. This means that the patient can't be distinguish that there are some series which are different among others in the executed blocks.

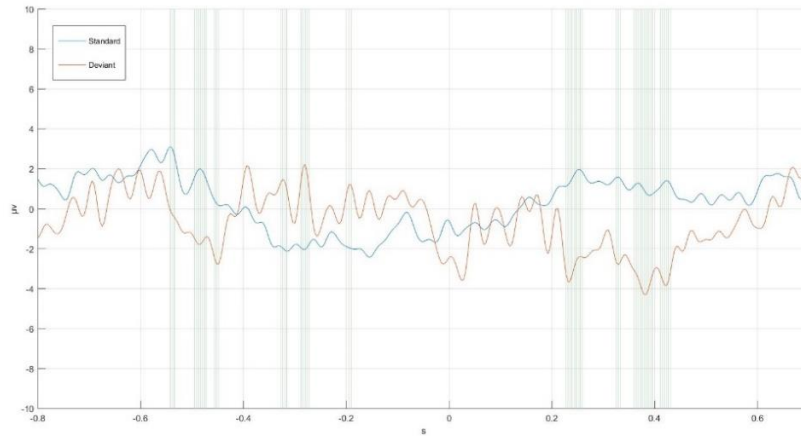

Figure 28: All channel averaged signal corresponding to the stroke patient from 800ms before the onset of the last sound in series to 700ms after. In blue global standard series are presented, in red the global deviant ones. Vertical lines showed a significant difference between standard and deviant series according to t-test statistics.

If the EEG acquisition from all channel averaged of a healthy person is compared (Figure 29), a clear positive peak corresponding to P300 ERP can be distinguish with the meaning the subject has learned that there are some rare series among standard ones. As expected, a negative peak appears in the range from 100ms to 190ms approximately, which corresponds to the N100 ERP one. EEG acquisition of each channel separately is also visualized (Annex 3).

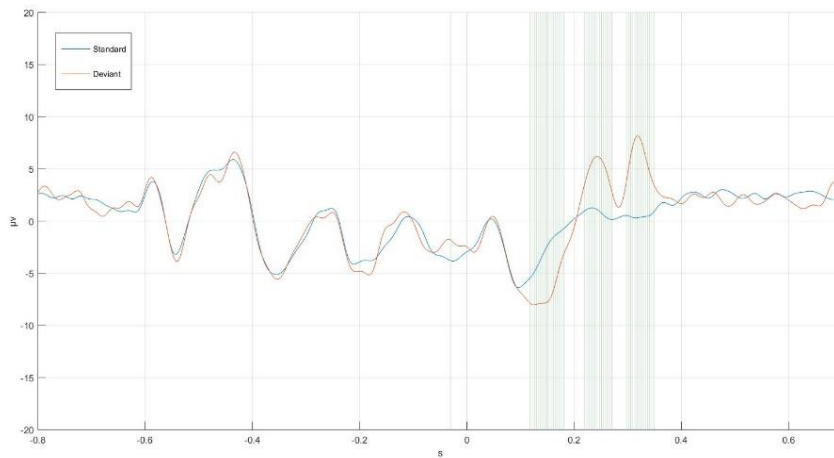

Figure 29: All channel averaged signal corresponding to a healthy person from 800ms before the onset of the last sound in series to 700ms after. In blue global standard series are presented, in red the global deviant ones. Vertical lines showed a significant difference between standard and deviant series according to t-test statistics.

According to the results and following the literature, patient with a stroke, although its brain disease, should has recognized the global regularity, as it is conscious. Then, the results of the artefact rejection have been also revised (Figure 30) in order to discard possible errors in the signal analysis, and it is can be observed that the acquisition has not been performed as well as possible. The number of artefacts is very high and, consequently, the percentages of local and global series which are eliminated are close to 50%.

```

Command Window
>> SignalProcessing

Artifact Information
|
Number of artifacts: 108
Number of artifacts in local standard: 46 (25.70 %)
Number of artifacts in local deviant: 62 (43.97 %)
Number of artifacts in global standard: 90 (34.22 %)
Number of artifacts in global deviant: 18 (31.58 %)
fx >>
    
```

Figure 30: Results of artefact detection from the EEG acquisition of the stroke patient.

Neither is there an obvious presence of the Mismatch Negativity when a difference between standard and deviant series is performed, but it was expected when the previous results have not been favourable. Again, a comparison with a healthy person is wanted to visualize and there is a soft negative peak distinguishable around 100ms after the onset of the fifth sound when a MMN should be appear (Figure 31).

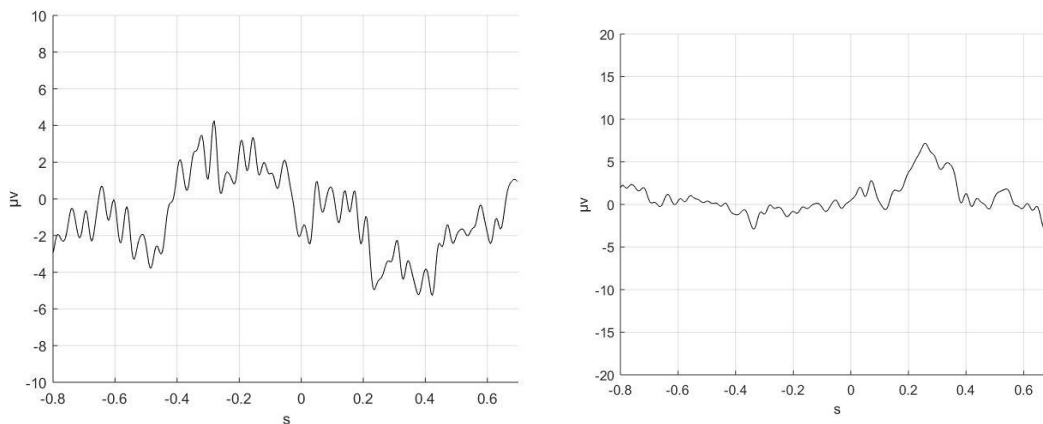

Figure 31: On the left, results of the MMN from stroke patient has been calculated. On the right, results of the MMN from healthy patient. Both of them are obtained doing the subtraction of global standard series from global deviant ones.

9.4.2 Local Effects

In response to local violations (Figure 32), not significant differences have been observed in the signal obtained from stroke patient. It can be said that there are a soft negative peak of the deviant series 100ms after the onset of the fifth sound, but it is not reaching the p-value of t-test statistics. A positive peak of deviant series appears after 200ms, anticipating the P300 ERP. After these events, the standard series signal acquires higher values than deviant signal one.

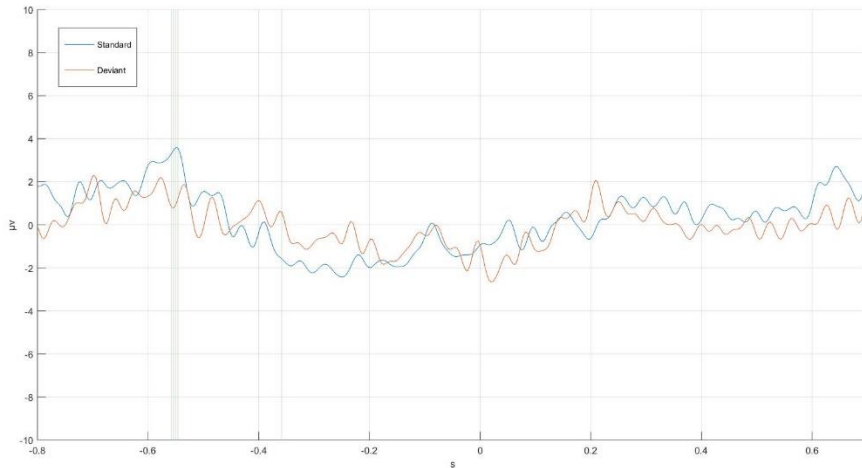

Figure 32: All channel averaged signal corresponding to a stroke person from 800ms before the onset of the last sound in series to 700ms after. In blue local standard series are presented, in red the local deviant ones. Vertical lines showed a significant difference between standard and deviant series according to t-test statistics.

If the same graphical representation from a healthy patient signal is presented, better results are obtained according to the literature since the peaks follows a desired shape. Around 100ms, it appears a remarkable negativity of deviant trials which is cannot distinguishable in the standard ones. The P300 event also appears unmistakably, but it follows the same pattern as in the EEG of stroke patient, since it appears 100 milliseconds before its turn, at approximately 200ms after the onset of the fifth sound.

It is important to have on mind that the local regularity can be more detectable since it is focused in each block.

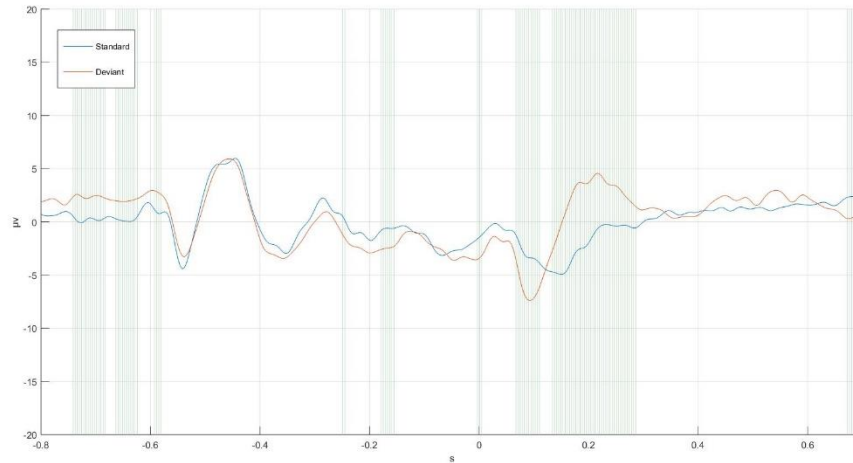

Figure 33: All channel averaged signal corresponding to a healthy person from 800ms before the onset of the last sound in series to 700ms after. In blue local standard series are presented, in red the local deviant ones. Vertical lines showed a significant difference between standard and deviant series according to t-test statistics.

As the Mismatch Negativity is related to the previous visualized and analysed signals and it is can be seen that the N100 of the stroke patient has not been distinguished so much, its MMN is not appreciable (Figure 34). However, in the case of healthy patient, its present is detected.

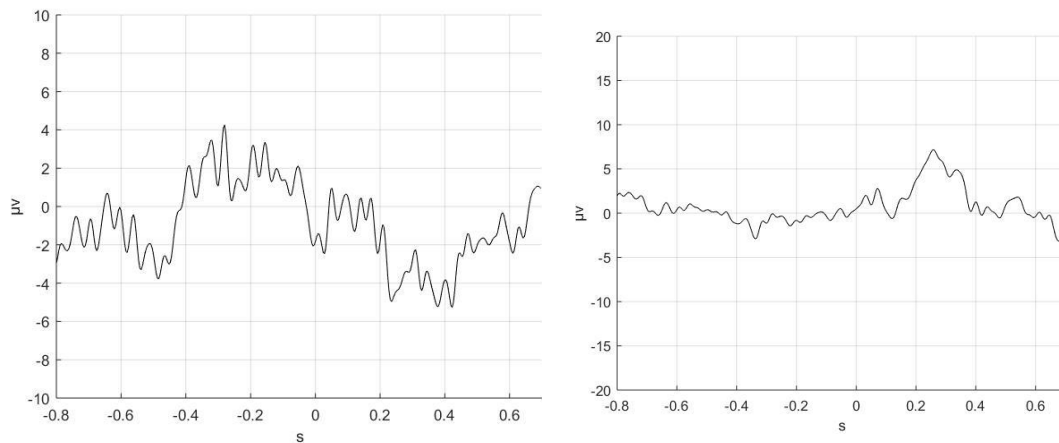

Figure 34: On the left, results of the MMN from stroke patient has been calculated. On the right, results of the MMN from healthy patient. Both of them are obtained doing the subtraction of global standard series from global deviant ones.

10 Conclusion

With this model, it is wanted to detect consciousness without relying on behavioural responses but analysing the neural responses when an auditory paradigm is presented. Our analysis is made with some healthy subjects and only one patient with a brain disorder, then we cannot do a correct comparison with patients with disorders in consciousness. However, the results that we have obtained gives us information about the responses in patients with signals of consciousness.

The Local-Global test is based on the global workspace theory of conscious processing [1-3] which postulates that consciousness is required to actively maintain perceptual information over time in working memory, and to engage strategical processes necessary to detect the global deviance occurrences. An important complementary condition is to demonstrate that the global effect does not occur in non-conscious patients in whom residual cognitive abilities are not engaged in an active distracting task.

As it is mentioned above, the designed paradigm from this project has not been possible to test with enough people to make assertions about the future diagnosis of patients with disorders of consciousness. However, following the literature, it is possible to ascertain the patterns in brain signal when an auditory stimulation has been presented. Then, results from global and local violations has been discussed.

On the one hand, violations of global regularities evoke less differences between standard and deviant responses than the local ones. It is seen that a N100 appears in both healthy and non-healthy subjects, but not significant P300 responses appears later in non-healthy global tests. Then, we can prove that in patients with disorders of consciousness should be difficult to detect a P300, which is related to the awareness that there is a deviant trial among standard one in each block. About the MMN, no coincident results have been obtained since in brain signals of both type of subjects it should be observed a peak given by the presence of an 'oddball', although there is no attention. It is important to take into account that in some blocks the global-deviant series are the ones with the five same sounds, then it is possible that this type of series don't provide the desired effect in brain potentials.

On the other hand, violations of local regularities elicited three successive ERP effects, the occurrence of which differed across tests. In the results of healthy subjects, N100 ERP takes a major amplitude than in the stroke patient test; these effects can be corroborating the evidence that N100 amplitude and significance seemed to be strongly related to the level of consciousness. Second, immediately following the N100 response, a positive response is observed which may well correspond to a P300 response. Indeed, the finding that this component was less significant in the global tests may be interpreted in terms of limited central capacity: when subjects were presented with the local deviant trials they may process this attribute without responding to the global deviance. About the MMN, the results obtained don't agree with theory, since it is known that an unexpected noise should be evoke an irregularity in brain signal.

The ERP global effect can be used as a highly specific marker of consciousness in non-communicating patients, being that it presents differences between healthy and parietic subjects and also with global and local regularities. According to the results, we can suppose that in the presence of a global effect in an individual clinically diagnosed as non-conscious, it is expected

some signs of consciousness in a few, but it is necessary to test the paradigm with a significant number of voluntaries, both healthy and with some disorder of consciousness. Also, it is should be necessary to observe the responses from non-communicating patients and ensure that the capture will be clean and free of artefacts.

In future analyses, this study must include patients with disorders of consciousness in order to make more realistic predictions.

11 References

- [1] J. D. Sitt *et al.*, “Large scale screening of neural signatures of consciousness in patients in a vegetative or minimally conscious state,” *Brain*, vol. 137, no. 8, pp. 2258–2270, 2014.
- [2] T. A. Bekinschtein, S. Dehaene, B. Rohaut, F. Tadel, L. Cohen, and L. Naccache, “Neural signature of the conscious processing of auditory regularities,” *Proc. Natl. Acad. Sci.*, vol. 106, no. 5, pp. 1672–1677, 2009.
- [3] N. Weiss, T. Bekinschtein, and F. Bolgert, “Probing consciousness with event-related potentials in vegetative state,” *Neurology*, vol. 77, pp. 264–269, 2011.
- [4] American Academy of Neurology (AAN), American Congress of Rehabilitation Medicine (ACRM), and R. R. (NIDILRR) Nationale Institute on Disability, Independent Living, “Summary of Evidence-based Guideline for Families and Caregivers Disorders of Consciousness Predicting Health Outcomes for DoC in Adults,” 2018.
- [5] nhs.uk. (2019). *Disorders of consciousness*. [online] Available at: <https://www.nhs.uk/conditions/disorders-of-consciousness/> [Accessed 14 Dec. 2018].
- [6] P. Wierzgała, D. Zapała, G. M. Wojcik, and J. Masiak, “Most Popular Signal Processing Methods in Motor-Imagery BCI: A Review and Meta-Analysis,” *Front. Neuroinform.*, 2018.
- [7] L. F. Nicolas-Alonso and J. Gomez-Gil, “Brain computer interfaces, a review,” *Sensors*. 2012.
- [8] A. Piarulli, V. Charland-Verville, and S. Laureys, “Cognitive auditory evoked potentials in coma: Can you hear me?,” *Brain*, 2015.
- [9] L.A Farwell and E. Donchin, “Talkinf off the top of yout head: toward a mental prosthesis utilizing event-related brain potentials,” *J. from Elsevier Sci. Publ. Irel.*, 1988.
- [10] sirasnik, “Supplementary Materials,” pp. 1–2, 2006.
- [11] M. I. Garrido, J. M. Kilner, K. E. Stephan, and K. J. Friston, “The mismatch negativity: A review of underlying mechanisms,” *Clin. Neurophysiol.*, vol. 120, no. 3, pp. 453–463, 2009.
- [12] R. Dinteren, M. Arns, M. L. A. Jongsma, and R. P. C. Kessels, “P300 development across the lifespan: A systematic review and meta-analysis,” *PLoS One*, 2014.
- [13] S. A. Hillyard and M. Kutas, “Electrophysiology of Cognitive Processing,” *Annu. Rev. Psychol.*, 1983.
- [14] Anon, (2019). [online] Available at: https://www.electronicstutorials.ws/amplifier/amp_1.html [Accessed 13 Dec. 2018].
- [15] En.wikipedia.org. (2019). *Operational amplifier*. [online] Available at: https://en.wikipedia.org/wiki/Operational_amplifier [Accessed 13 Dec. 2018].
- [16] Turkey Alotaiby, Fathi E ABD El-Samie, Saleh A Alshebeli, and Ishtiaq Ahmad, “A review of channel selection algorithms for EEG signal processing,” 2017.

- [17] S. Steven W., *The Scientist and Engineer's Guide to Digital Signal Processing*. San Diego, California, 1999.
- [18] Shodhganga, "CHAPTER-2 NOTCH FILTER DESIGN TECHNIQUES."
- [19] A. A. Sadiq *et al.*, "Fourth-Order Butterworth Active Bandpass Filter Design for Single-Sided Magnetic Particle Imaging Scanner," *J. Telecommun. Electron. Comput. Eng.*, vol. 10, no. 1–17, pp. 17–21, 2018.
- [20] S. Kanoga and Y. Mitsukura, "Review of Artifact Rejection Methods for Electroencephalographic Systems," in *Electroencephalography*, 2017.
- [21] Statistics How To. (2019). *T Test (Student's T-Test): Definition and Examples - Statistics How To*. [online] Available at: <https://www.statisticshowto.datasciencecentral.com/probability-and-statistics/t-test/> [Accessed 18 Dec. 2018].
- [22] g.ec medical engineering GmbH, *g.tec product catalogue 2016_web_gBSanalyze*. 2016.
- [23] compsoft-sysmatlab Newsgroup, "Anonymous FTP server Product enhancement suggestions Subscribing user registration," 1998.
- [24] C. Pan, R. Zhang, H. Luo, and H. Shen, "Baseline correction of vibration acceleration signals with inconsistent initial velocity and displacement," *Adv. Mech. Eng.*, 2016.

12 Annex

	1	2	3	4	5	6	7	8	9	10	11	12	13	14	15	16	17	18	19	20	21	22	23	24	25
1	0	0.0039	0.0078	0.0117	0.0156	0.0195	0.0234	0.0273	0.0313	0.0352	0.0391	0.0430	0.0469	0.0508	0.0547	0.0586	0.0625	0.0664	0.0703	0.0742	0.0781	0.0820	0.0859	0.0898	0.0938
2	223.5492	88.1282	62.8954	16.5789	-16.3868	16.1050	18.4535	15.7875	0.1148	-15.4173	-8.1889	11.6612	12.5944	-0.9388	-6.7795	-2.7670	18.9463	17.0277	7.7309	41.1926	11.1955	18.8414	35.0401	17.1386	4.5601
3	257.6583	947.39e+	-1.2714e+	305.4095	-60.5506	6.9319	20.7220	14.0229	-5.5597	-24.4971	-749.74	13.5090	15.6154	-4.1206	16.7268	-16.0742	15.3104	19.0340	5.1447	-1.7718	3.6352	18.9457	41.3351	22.1467	5.4466
4	140.4236	1.0816e+	-1.4950e+	266.9778	112.7395	-41.5321	-26.2637	-33.1261	-52.1871	-71.1837	-53.1477	-33.0843	-29.8232	-55.3102	-69.9793	-65.7284	-25.3198	-30.3657	-42.0703	-54.7758	-49.3850	-33.3285	-58.8860	-27.4111	-51.0294
5	176.4357	982.2418	80.9977	-41.8411	-91.7641	-71.7389	-60.7979	-52.2493	-66.0440	-87.1588	-78.0774	-63.1240	-52.8912	-60.3351	-75.7855	-84.3222	-56.5524	-49.7806	-60.1773	-70.0820	-70.8288	-62.2336	-38.9300	-47.6371	-67.8554
6	-118.8036	-6.0716e+	782.0289	-293.9792	-100.3191	-122.4652	-111.1966	-91.5291	-106.5059	-134.8148	-133.5475	-115.5267	-97.6933	-103.4476	-123.9916	-137.9043	-113.3981	-93.1889	-95.3540	-110.6511	-122.6830	-109.5067	-76.3393	-84.3226	-107.9597
7	-509.3675	-1.0492e+	-1.2544e+	-237.5826	-25.2567	-65.3332	-56.2508	-36.8813	-56.3834	-82.0642	-77.0603	-57.0359	-42.1888	-80.8534	-71.9482	-84.2325	-55.7100	-37.1787	-41.1236	-56.6814	-66.3166	-50.4405	-20.4918	-28.0889	-52.6758
8	-235.1841	1.1783e+	-1.6970e+	237.4591	-116.2156	-81.1288	-49.5956	-57.5648	-74.0502	-100.3259	-84.6587	-57.6196	-49.4594	-70.4538	-86.5067	-85.3648	-54.2435	-45.1371	-55.3994	-71.1396	-70.9009	-46.8638	-20.8167	-38.4534	-62.9000
9	-504.6817	-1.0516e+	1.2316e+	-368.9746	-26.5235	-48.4246	-44.6626	-37.3800	-66.0325	-83.8496	-63.7915	-40.4398	-39.7772	-65.5723	-78.6522	-71.4512	-37.5204	-36.3574	-50.9997	-60.5702	-55.1799	-33.0784	-12.7476	-35.6492	-57.0511
10	-193.7182	9.3682e+	-1.3048e+	222.6248	-42.3587	0.6351	23.2175	12.6182	-6.7219	-23.8812	-4.4473	17.7733	16.6889	-12.9509	-20.2132	-14.4384	20.2613	20.2934	4.6113	-9.0731	-1.2376	19.4595	40.0726	14.3586	-7.0612
11	449.2046	208.5552	147.7125	45.5374	-9.5527	49.2554	37.7527	36.4994	9.7432	1.4309	28.0086	51.6240	43.3436	0.3240	3.9958	15.6970	49.9400	44.0734	23.0612	9.0697	24.5124	48.3111	68.4461	23.4971	9.3567
12	429.1061	-1.1701e+	232.0382	-27.7043	-69.9877	-17.1679	-17.6498	-21.9745	-46.7457	-56.7245	-35.8948	-16.0495	-23.2944	-44.2349	-52.9712	-43.7138	-13.4393	-13.9212	-34.4686	-41.2623	-29.3904	-10.4667	-0.7223	-25.2408	-41.0994
13	576.1868	2.8831e+	-251.8121	22.7786	-148.6579	-99.9719	-86.6100	-79.9263	-100.1551	-126.3785	-116.5141	-92.4121	-79.0051	-98.1523	-118.1864	-121.2865	-88.2156	-74.0250	-86.0894	-105.9510	-105.8662	-85.6516	-58.8805	-75.4427	-101.1321
14	-211.6619	962.0073	-199.9245	-36.7386	-64.7153	-57.2594	-36.8400	-32.8805	-51.2688	-77.1607	-69.1115	-41.6622	-33.0255	-48.7781	-65.9100	-69.7863	-38.2750	-27.6893	-35.4936	-52.7389	-55.4849	-35.3262	-9.0631	-24.3781	-50.6729
15	-262.8796	1.4062e+	-333.2759	-66.8088	-110.2845	-97.6772	-78.5290	-75.5347	-99.7865	-118.8473	-104.3203	-83.3733	-75.8303	-95.7980	-109.3318	-109.9831	-79.3116	-73.2875	-83.7903	-97.3092	-96.0856	-75.7380	-51.0405	-68.3556	-89.4316
16	482.5640	32.9261	95.4147	-45.1071	-123.9649	-74.7538	-72.1850	-67.1322	-93.1577	-111.2601	-93.4710	-70.8697	-68.1408	-84.6651	-105.2928	-99.3212	-66.5911	-62.7542	-78.2864	-96.2749	-91.8180	-68.2432	-45.9119	-71.3860	-91.7676
17	-292.0139	275.5959	-194.9369	-107.9522	-111.9545	-94.4109	-77.2020	-82.4316	-108.0614	-128.3362	-115.4775	-95.3172	-92.9453	-113.1291	-125.8202	-124.0272	-92.3830	-88.8606	-107.7310	-121.6480	-116.6398	-95.6805	-77.8987	-97.7719	-117.3157
18	0	0	0	0	0	0	0	0	0	0	0	0	0	0	0	0	0	0	0	0	0	0	0	0	0
19	0	0	0	0	0	0	0	0	0	0	0	0	0	0	0	0	0	0	0	0	0	0	0	0	0
20	0	0	0	0	0	0	0	0	0	0	0	0	0	0	0	0	0	0	0	0	0	0	0	0	0
21																									
22																									
23																									
24																									
25																									
26																									
27																									
28																									
29																									
30																									

Annex 1: Resulting file after performing the acquisition through Simulink model. First row corresponds to the time of acquisition according to the sampling frequency; next 16 channels correspond to the EEG cap channels connected to the amplifier, the next two correspond to the trigger plot and trigger generated by the model respectively; and finally, the last row shows the number of current block.

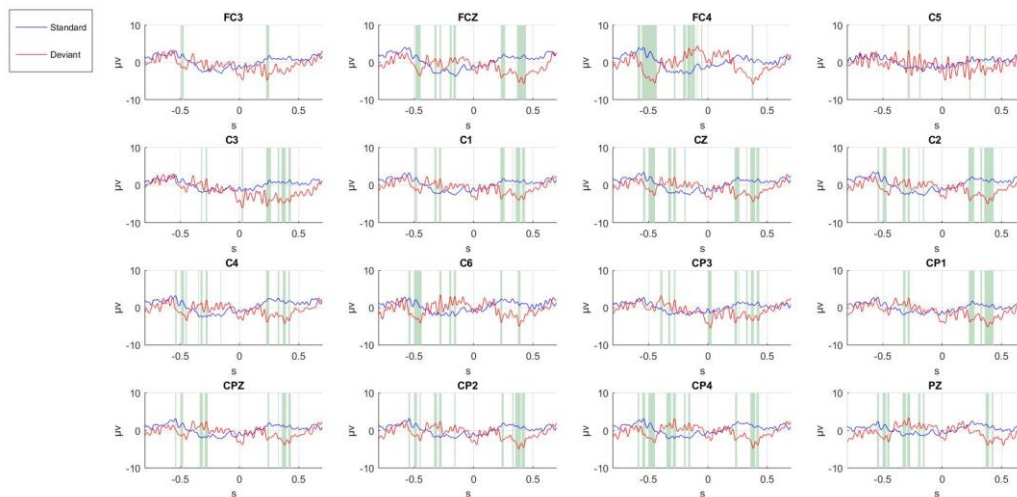

Annex 2: Every channel analysed signal separately corresponding to the stroke patient from 800ms before the onset of the last sound in series to 700ms after. In blue global standard series are presented, in red the global deviant ones. Vertical lines showed a significant difference between standard and deviant series according to t-test statistics. It is can observed that approximately all channels will follow the same pattern. Also, some channel like C5 can be detected with the presence of artefacts.

LOCAL-GLOBAL PARADIGM: AUDITORY NEUROSTIMULATION

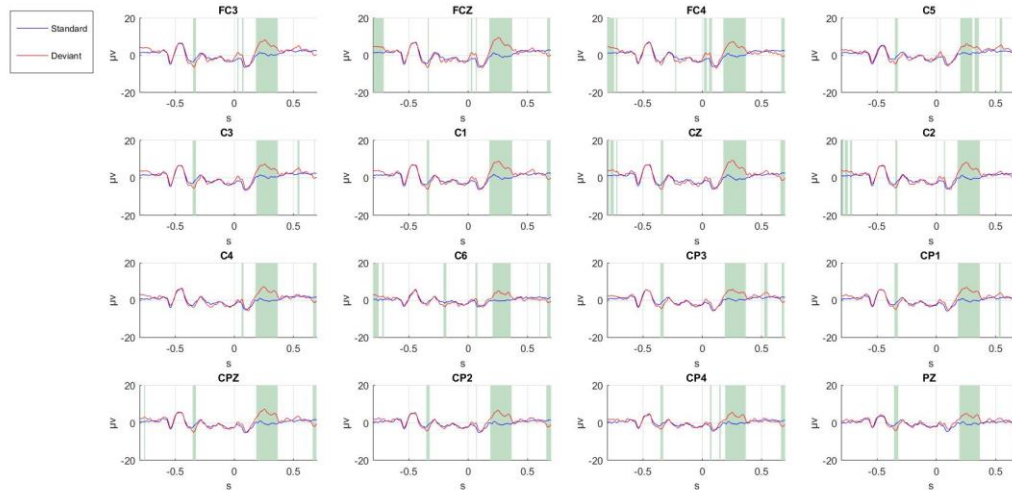

Annex 3: Every channel analysed signal separately corresponding to a healthy patient from 800ms before the onset of the last sound in series to 700ms after. In blue global standard series are presented, in red the global deviant ones. Vertical lines showed a significant difference between standard and deviant series according to t-test statistics. In all channels the presence of P300 is clearly detected. Though, N100 is not as distinguishable as in the median of all channels.

Other results from voluntaries:

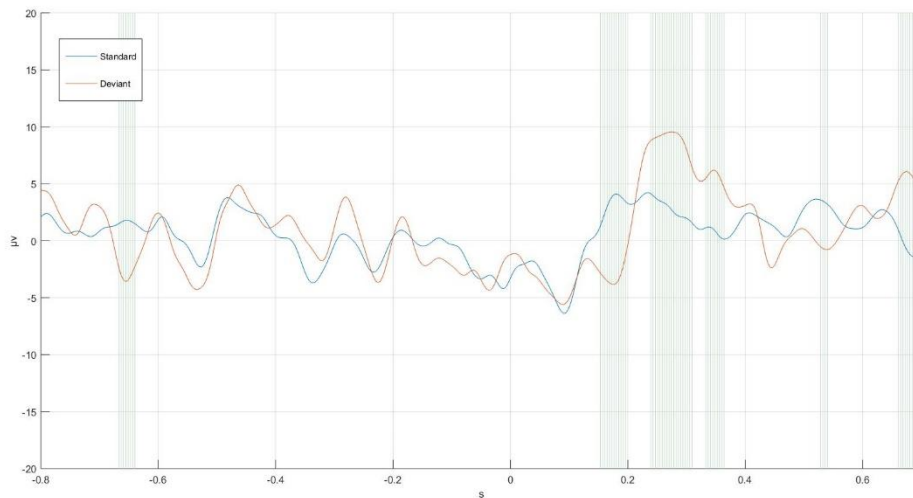

Annex 4: All channel averaged signal corresponding to a healthy person from 800ms before the onset of the last sound in series to 700ms after in response to global violations. In blue global standard series are presented, in red the global deviant ones. Vertical lines showed a significant difference between standard and deviant series according to t-test statistics. A very clear P300 response is visualized. N100 appears with delay at approximately 200ms after deviant sound.

LOCAL-GLOBAL PARADIGM: AUDITORY NEUROSTIMULATION

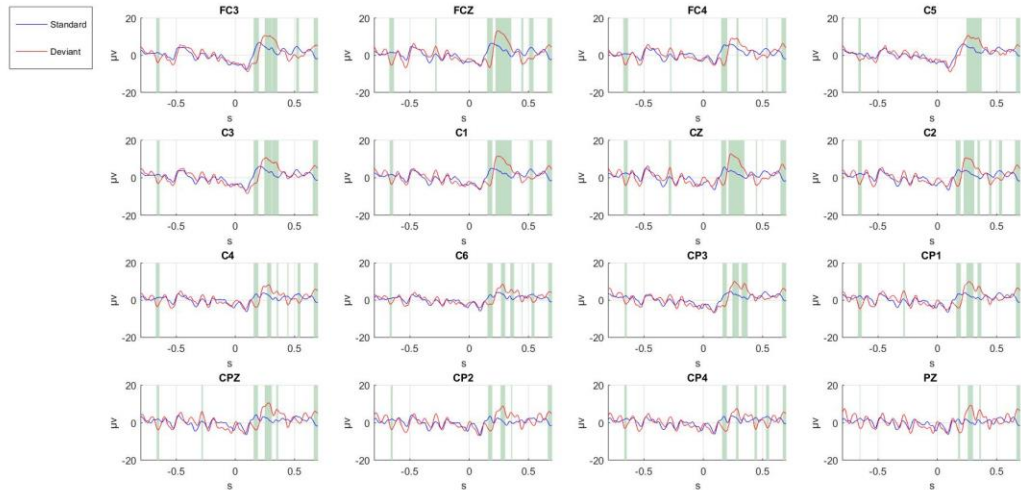

Annex 5: Every channel analysed signal separately corresponding to the same healthy voluntary as the previous figure from 800ms before the onset of the last sound in series to 700ms after. In blue global standard series are presented, in red the global deviant ones. Vertical lines showed a significant difference between standard and deviant series according to t-test statistics. In some channels like FC4 and CP4 the P300 is not as distinguishable than the others. In other site, the N100 is also more remarkable in some channels.

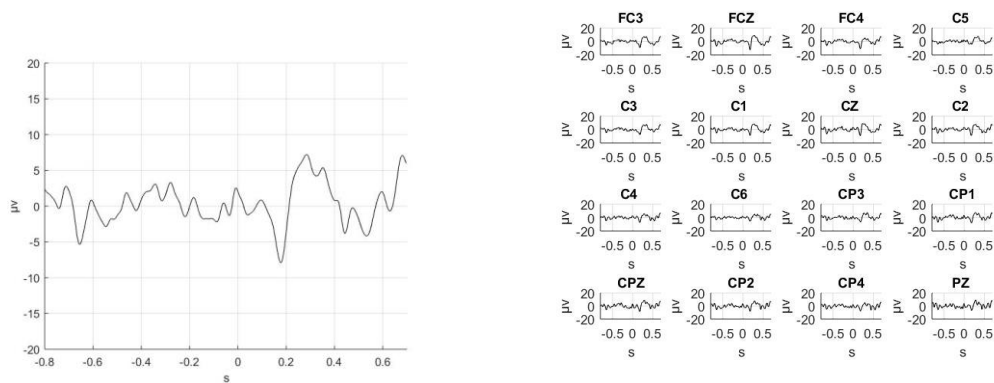

Annex 6: On the left, MMN of the all channels averaged from healthy patient. On the right, results of the MMN of each channel.

LOCAL-GLOBAL PARADIGM: AUDITORY NEUROSTIMULATION

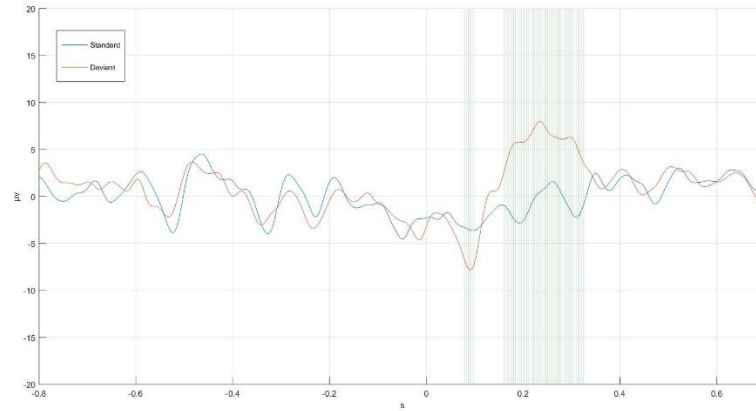

Annex 7: All channel averaged signal corresponding to a healthy person from 800ms before the onset of the last sound in series to 700ms after in response to local violations. In blue global standard series are presented, in red the global deviant ones. Vertical lines showed a significant difference between standard and deviant series according to t-test statistics. A very clear N100 and P300 response is visualized.

Voluntary 2:

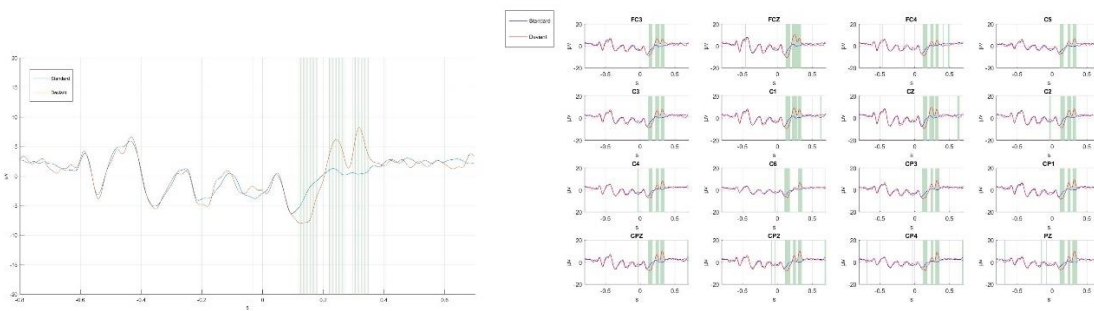

Annex 8: On the left, the averaging of all channel in response to global violations from healthy voluntary. On the right, every channel with EEG signal from the same person. Both N100 and P300 are evoked.

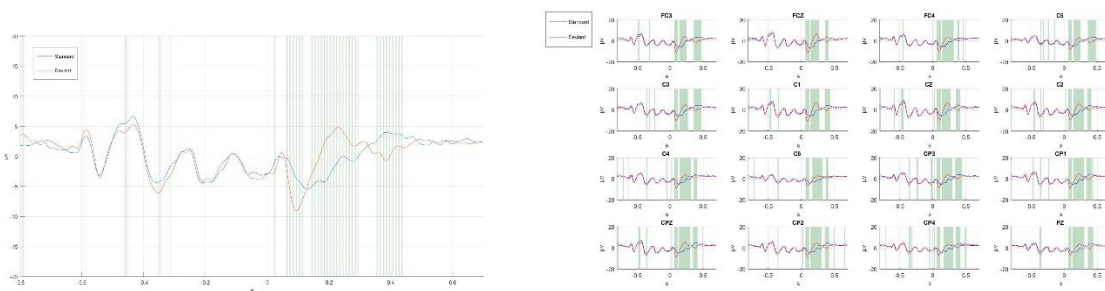

Annex 9: On the left, the averaging of all channel in response to local violations from healthy voluntary. On the right, every channel with EEG signal from the same person. P300 appears earlier than normal.

13 Video



Demo Final Degree Project Lorena Casanova Lozano

Link:

<https://youtu.be/j58nA16-nu4>

